

**PANDIT SUNDARLAL SHARMA (OPEN) UNIVERSITY CHHATTISGARH
BILASPUR**



LABORATORY MANUAL

Bachelor of Science

Physics

(B.Sc. Ist Year)

Department of Physics

PANDIT SUNDARLAL SHARMA (OPEN) UNIVERSITY CHHATTISGARH, BILASPUR

VERIFIED

Dr. Anita Singh

Incharge NAAC Criteria-I

PSSOU, CG Bilaspur

REGISTRAR
Pt. Sunderlal Sharma (Open)
University Chhattisgarh
BILASPUR (C.G.)

**PANDIT SUNDARLAL SHARMA (OPEN) UNIVERSITY
CHHATTISGARH, BILASPUR**



LABORATORY MANUAL

**TO DETERMINE THE MODULUS OF RIGIDITY
OF
THE MATERIAL OF WIRE BY TORSIONAL PENDULUM**

DR. POORAN SINGH CHOWDHARY

(M.Sc., Ph.D., LL.B.)

DEPARTMENT OF PHYSICS

***PANDIT SUNDARLAL SHARMA (OPEN) UNIVERSITY
CHHATTISGARH, BILASPUR***

AIM OF THE EXPERIMENT:

To determine the modulus of rigidity of the material of wire by Torsional pendulum.

APPARATUS REQUIRED:

Torsional pendulum, stop watch, vernier calipers, metre scale, screw gauge

THEORY OF EXMERIMENT:

A torsional pendulum, or torsional oscillator, consists of a disk-like mass suspended from a thin rod or wire. When the mass is twisted about the axis of the wire, the wire exerts a torque on the mass, tending to rotate it back to its original position. If twisted and released, the mass will oscillate back and forth, executing simple harmonic motion. This is the angular version of the bouncing mass hanging from a spring. This gives us an idea of moment of inertia. We try to calculate the moment of inertia of a ring given the moment of a disc. We can also verify the perpendicular axis theorem and compare it with theoretically calculated values.

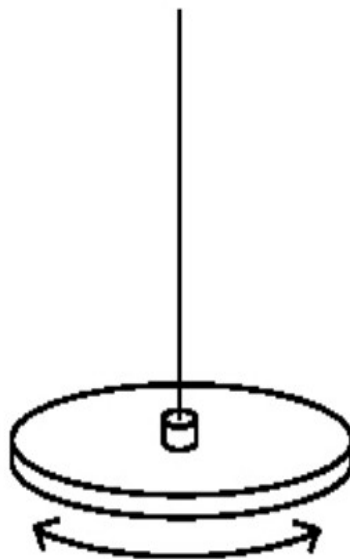

The working is based on the torsional simple harmonic oscillation with the analogue of displacement replaced by angular displacement θ , force by Torque τ and the spring constant by torsional constant κ . For a given small twist θ (sufficiently small), the experienced reaction is given by

$$\tau = -\kappa\theta$$

This is just like the Hooke's law for the springs. If a mass with moment of inertia I is attached to the rod, the torque will give the mass an angular acceleration α according to $\tau = I (d^2\theta / dt^2)$.

Hence we get the relation: $d^2\theta / dt^2 = -\kappa\theta / I$

Hence on solving this second order differential equation we get $\omega = \sqrt{\kappa/I}$

Hence we have $T = 2\pi\sqrt{I/\kappa}$ where I is the length of suspension. This is our governing equation of the experiment.

PROCEDURE:

Initially we hang the disc alone and give a small angular displacement to the system and leave it to oscillate after fixing a fixed length of suspension. Then measure the time period of oscillation of (say) 7 or 10 oscillations and then take the average so as to minimize the error due to our reaction time and precision of the pendulum. Measure the time period for various lengths.

Now hang the ring along with disc and follow the same procedure as before to find the Time Periods for various lengths. We can find the theoretical values of the moment of inertia of ring and disc by knowing their mass and the radii by the following equations:

$$I_{\text{disc}} = M_{\text{disc}}R^2 / 2$$

$$I_{\text{ring}} = M_{\text{ring}} (R_{\text{in}}^2 + R_{\text{out}}^2) / 2$$

Now, we can take the ratio of Time period of disc alone with the time period of disc alone with ring and calculate the ratio of I_{ring} and I_{disc} and tally it with the theoretical value. From this we can assume one of the values of Inertia and find the other.

From the graph of T^2 and I we can find the value of κ by knowing the values of I . Hence, we can use different wires in the experiment and repeat the experiment and find the values of κ of the material of the wire.

We can repeat the first step with just the ring alone hung along its diameter instead of the radial axis and find the time periods for various lengths. From this we can compare the value of Moment of Inertia to that predicted by perpendicular axis theorem. Here, we expect the I along diametrical axis to be half that of I in the perpendicular direction to the plane of the ring (because $I_x + I_y = I_z$ and here $I_x = I_y$ as they are the same axis).

OBSERVATIONS:

The dimensional measurements made:

- (1) Radius of the Disc $R_{disc} =$
- (2) Outer Radius of the Annulus $R_{out} =$
- (3) Inner Radius of the Annulus $R_{in} =$
- (4) Diameter of the Brass Wire $d_{brass} =$
- (5) Diameter of the Steel Wire $d_{steel} =$
- (6) Mass of the Disc $M_{disc} =$
- (7) Mass of the ring $M_{ring} =$
- (8) Moment of Inertia of the Disc (theoretically) $= I_{disc}$

(9) Moment of Inertia of the Ring (theoretically) = I_{ring}

(10) Theoretically $I_{\text{ring}} / I_{\text{disc}} =$

OBSERVATION TABLES:

Measurements of Time period for various lengths using a disc hung on a brass wire:

S. No.	Length (cm)	Time for 25 Oscillations (sec)	Time Period (sec)
01			
02			
03			
04			

Measurements of the Time period for various lengths of a brass wire with the ring with annulus:

S. No.	Length (cm)	Time for 25 Oscillations (sec)	Time Period (sec)
01			
02			
03			
04			

Measurements of Time Period for various lengths of steel wire with the disc hung:

S. No.	Length (cm)	Time for 25 Oscillations (sec)	Time Period (sec)
01			
02			
03			
04			

Measurements of Time period for various lengths of steel wire with the disc and the annulus hung:

S. No.	Length (cm)	Time for 25 Oscillations (sec)	Time Period (sec)
01			
02			
03			
04			

Measurements of T for various lengths for a ring along its diameter

S. No.	Length (cm)	Time for 25 Oscillations (sec)	Time Period (sec)
01			
02			
03			
04			

CALCULATIONS:

(1) Slope of the graph of T^2 versus l for the first table of data is:

(2) Slope of the graph of T^2 versus l for the second table of data is:

(3) Experimentally, the ratio $I_{ring} / I_{disc} =$

(4) Slope of the graph of T^2 versus l for the third data table is:

(5) Slope of the graph of T^2 versus l for fourth data table is:

(6) The ratio of $I_{ring} / I_{disc} =$

Here, the ratio I expected to be bad because there was a lot of wobbling with the steel wire under the very heavy weight and also non-centering of the wire in the 4 RAVITEJ UPPU suspension places because the wire was slipping when fixed in the center of the fixtures.

RESULT:

The modulus of rigidity of the material of the given wire is found =
dynes/cm²

PRECAUTIONS:

- (1) The bob/disc of pendulum should be displaced with a small angle.
- (2) The amplitude of the oscillation of a pendulum should be small.
- (3) Fans should be switched off to reduce the air resistance.
- (4) The pendulum should be twisting in a horizontal plane only.
- (5) The length of the suspended wire should be sufficient.

(2) Slope of the graph of T^2 versus l for the second table of data is:

(3) Experimentally, the ratio $l_{ring} / l_{disc} =$

(4) Slope of the graph of T^2 versus l for the third data table is:

(5) Slope of the graph of T^2 versus l for fourth data table is:

(6) The ratio of $l_{ring} / l_{disc} =$

Here, the ratio I expected to be bad because there was a lot of wobbling with the steel wire under the very heavy weight and also non-centering of the wire in the 4 RAVITEJ UPPU suspension places because the wire was slipping when fixed in the center of the fixtures.

RESULT:

The modulus of rigidity of the material of the given wire is found =
..... dynes/cm²

PRECAUTIONS:

- (1) The bob/disc of pendulum should be displaced with a small angle.
- (2) The amplitude of the oscillation of a pendulum should be small.
- (3) Fans should be switched off to reduce the air resistance.
- (4) The pendulum should be twisting in a horizontal plane only.
- (5) The length of the suspended wire should be sufficient.

VERIFIED

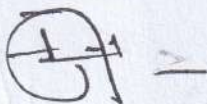

Dr. Anita Singh
Incharge NAAC Criteria-I
PSSOU, CG Bilaspur

**PANDIT SUNDARLAL SHARMA (OPEN) UNIVERSITY CHHATTISGARH
BILASPUR**



LABORATORY MANUAL

Bachelor of Science

Physics

(B.Sc. IInd Year)

Department of Physics

PANDIT SUNDARLAL SHARMA (OPEN) UNIVERSITY CHHATTISGARH, BILASPUR

VERIFIED

Dr. Anita Singh

Incharge NAAC Criteria-I

PSSC, UG Bilaspur

REGISTRAR
Pt. Sunderlal Sharma (Open)
University Chhattisgarh
BILASPUR (C.G.)

**PANDIT SUNDARLAL SHARMA (OPEN) UNIVERSITY
CHHATTISGARH, BILASPUR**



LABORATORY MANUAL

**DETERMINING WAVELENGTH OF SPECTRAL LINES
WITH PLANE TRANSMISSION GRATING
BY
MINIMUM DEVIATION METHOD**

DR. POORAN SINGH CHOWDHARY

(M.Sc., Ph.D., LL.B.)

DEPARTMENT OF PHYSICS

***PANDIT SUNDARLAL SHARMA (OPEN) UNIVERSITY
CHHATTISGARH, BILASPUR***

OBJECT:

To determine the wavelength of different spectral lines of mercury light with the help of plane transmission grating by minimum deviation method.

APPARATUS REQUIRED:

Spectrometer, diffraction grating of known grating element, mercury lamp, a reading lens and spirit level.

DESCRIPTION OF APPARATUS:

SPECTROMETER:

This is an arrangement for producing pure spectrum. The essential parts of a spectrometer include collimator, grating table, and a telescope (Figure 1).



Figure 1: Spectrometer arrangement

(A) Collimator:

The collimator provides a narrow parallel beam of light. It consists of a horizontal, cylindrical, metallic tube fitted with an achromatic convergent lens at one end and a short coaxial tube at the other end. The short coaxial tube is provided with a vertical slit of adjustable width at the outer end, can be moved inside the main tube with the help of a rack and pinion arrangement. The slit is illuminated by the source of light, whose spectrum is to be examined and the distance between the slit and the convergent lens is so adjusted that the slit lies in the first focal plane of the lens. Under this condition, the rays of light emerging from the collimator are parallel. Usually in a spectrometer, the Collimator is rigidly fixed with its axis horizontal, but in some instrument it can be rotated about the vertical axis passing through the center of instrument.

(B) Grating Table:

It is a circular table supported horizontally on a vertical rod at the center of the spectrometer. It can be rotated independently of the collimator and telescope about the vertical axis passing through the instrument's center of a circular scale graduated in half degrees carried by the telescope. The rotation of the grating table can be read with the help of two diametrically opposite vernier attached to it and sliding over the circular scale. The grating table can be clamped with the help of a clamping screw and then a fine rotation can be given to it with the help of a tangent screw provided at the base. The grating table can be raised or lowered and maybe clamped at any desired height with the help of a clamping screw provided for it. It is also provided with the three leveling screws so that the refracting faces of the grating can be adjusted parallel to the axis of instrument. Concentrating circles and straight lines parallel to the line joining any two of the leveling

screws are drawn on the surface of the grating table, which help in placing the grating in proper position during the experiment.

(C) Telescope:

It is simple astronomical telescope and consists of a horizontal, cylindrical metallic tube fitted with an achromatic convergent lens (called the objective) at one end and a short coaxial tube called eyepiece tube at the end. The eyepiece tube (provided with the cross-wires and Ramsden eyepiece) can be moved inside the main tube with the help of rack and pinion arrangement. Pulling or pushing the eyepiece in eyepiece tube by hand can also change the distance between the cross-wires and the eyepiece. Thus the telescope can be adjusted to receive parallel rays and to form a clear image upon the cross-wires, which are distinctly visible through the eyepiece. The telescope can be rotated about the central axis of the instrument. It is also provided with a clamping and a tangent screw at the base by which a slow rotation can be given to it. The main circular scale is attached with the telescope so that when the telescope is rotated, the main circular scale also rotates with it. The angle, through which the telescope is rotated, can be measured by reading the positions of the verniers attached to the grating table and sliding over the main scale.

PLANE TRANSMISSION GRATING:

An arrangement, which is equivalent in its action to a large number of parallel slits of same width separated by equal opaque spaces, is called diffraction grating. It is constructed by ruling fine equidistant parallel lines on an optically plane glass plate with the help of a sharp diamond point. The gratings used in the laboratory are usually replica gratings made from the original grating. The number of ruled lines in a grating varies from 15000 to 30000 per inch and the ruled surface varies from 2" to 6".

GRATING ELEMENT:

The distance between the centers of any two consecutive ruled lines or transparent spaces acting as a slit is called grating element. For example, let e be the width of the transparent space and d is the width of ruled space, then the grating element = $(e + d)$.

MEASUREMENT OF ANGLES BY SPECTROMETER:

The spectrometer scales are angle measuring utilities for the positions of the telescope which can be rotated about the central axis of the instrument. The main circular scale is attached with the telescope so that when the telescope is rotated, the main circular scale also rotates with it. The angle, through which the telescope is rotated, can be measured by reading the positions of the verniers attached to the grating table and sliding over the main scale. In a spectrometer there are two sets of main circular scales (fitted with the telescope) and Vernier scale (attached with grating table). Both sets are diagonally (left hand and right hand sides) fixed in the instrument and measures angle for a particular telescope position with a difference of 180 degrees. These scales can be used in a similar manner as a simple Vernier Caliper or traveling microscope is used. The Vernier caliper or traveling microscope is used to measure small distances (in centimeters and fractions) whereas spectrometer scales are used to measure small angular displacements (in degrees, minutes, and seconds). 1 degree is equal to 60 minutes and 1 minute is equal to 60 seconds.

LEAST COUNT OF THE SPECTROMETER SCALE:

- (i) 60 divisions of Vernier scale are equal to 59 divisions of the main scale.
- (ii) Value of one division of circular main scale = $0.5^\circ = 30'$ (as $1^\circ = 60'$).

(iii) Least Count of spectrometer scale = Value of 1 div. of main scale – value of 1 div. of Vernier = $0.5^\circ - [(59/60) \times 0.5]^\circ = [0.5 \times 1/60]^\circ = 0.5' = 30''$ (seconds).

MINIMUM DEVIATION METHOD:

THEORY:

Let a beam of light of wavelength ' λ ' is incident making an angle ' i ' with the normal to the plane of the diffraction grating be diffracted through an angle ' θ ' (Figure 2).

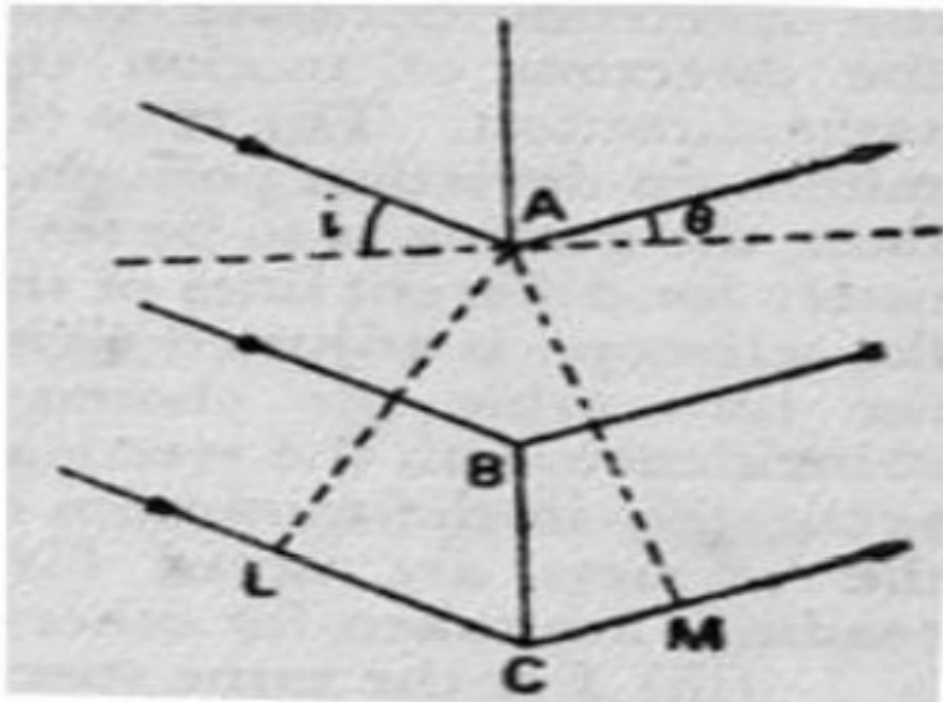

Figure 2

The path difference between the diffracted rays from consecutive points (i.e., from A and C) of transparent spaces

$$= LC + CM = e + d (\sin i + \sin \theta) \dots\dots\dots (1)$$

Where, $AC = e + d$ is the grating element.

Now for the n^{th} order spectrum, the condition is given by

$$(e + d) (\sin i + \sin \theta) = n\lambda \dots\dots\dots (2)$$

$$\text{Or, } 2(e + d) \{\sin [(i+\theta)/2]\} \{c[(i-\theta)/2]\} = n\lambda$$

$$\{\sin [(i+\theta)/2]\} = n\lambda / \{2(e+d) c[(i-\theta)/2]\}$$

$$\text{Or, } \sin D/2 = n\lambda / \{2(e+d) c[(i-\theta)/2]\}$$

Where, $D = \text{Angle of deviation} = i + \theta$

The value of $\sin (i+\theta)/2$ is minimum when $\cos (i-\theta)/2$ is maximum i.e., when $i = \theta$

If D_m is the angle of minimum deviation of the diffracted beam from its original path, then $D_m = i + \theta = 2i$ (since $i = \theta$ at minimum deviation).

When the grating is used in the minimum deviation position, the eqn. (2) gives

$$2(e + d) [\sin (D_m / 2)] = n\lambda$$

$$\text{Or, } (2 \times 2.54 / N) [\sin (D_m / 2)] = n\lambda \dots\dots\dots (3)$$

where N is the total number of lines per inch on the grating.

PROCEDURE:

The whole experiment is divided into two parts:

- (A) Adjustments
- (B) Measurement of the diffraction angle θ
- (I) Adjustments:

Before doing any measurement with the spectrometer, the following adjustments must be made in a given sequence.

- (a) The optical axes of the telescope and collimator should be perpendicular to the axis of rotation of the turn table and should meet it at the same point.
- (b) The telescope should be focused for parallel rays.
- (c) The collimator should be adjusted for rendering the rays from the illuminated slit parallel (Figure 3).

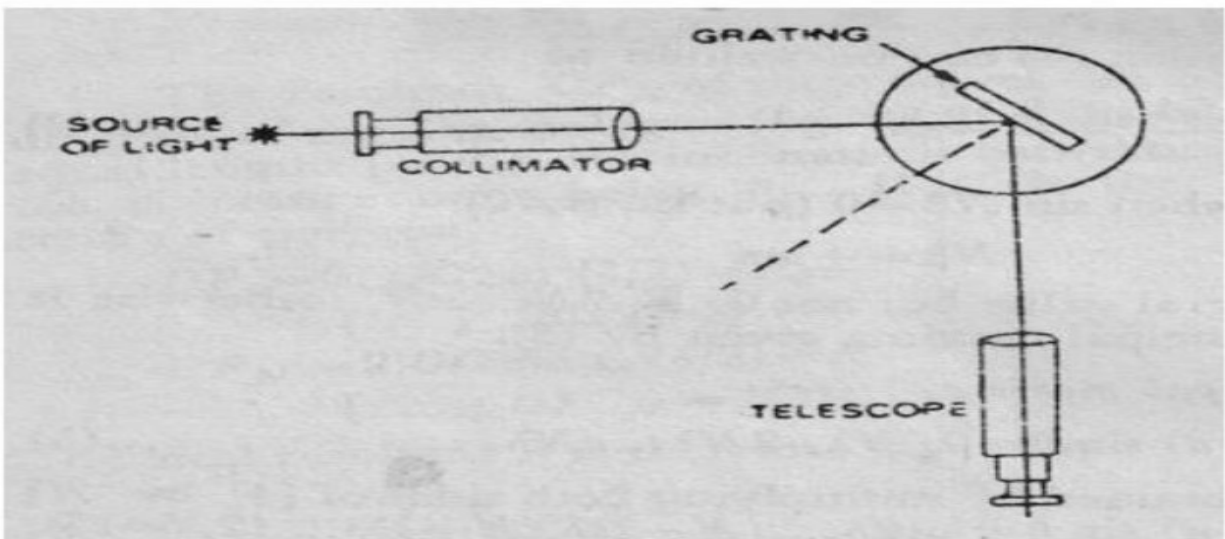

Figure 3

(II) Measurement of the Angle of Minimum Deviation:

(i) The turn table is rotated (carrying the grating) in a direction such that the spectrum of the first order moves towards the direct image of the slit. The telescope is moved to follow the spectrum of the slit in the field of view. A stage is reached when the spectrum becomes stationary for a moment and then reverses the direction of motion though the turn table is rotated in the same direction. The turn table and the telescope are clamped in the minimum deviation position. Since θ is different for different spectral lines, the grating is to be set in the minimum deviation position separately for different lines of the spectrum. The slit is made narrow and the telescope is adjusted (with the tangent screw) so that on rotating the turn table the

chosen spectral line (say, red) just comes in coincidence with the vertical cross-wire. The grating is now set accurately in the minimum deviation position. The readings of both the verniers are noted for this position of the telescope. Similar readings are taken for other spectral lines.

(ii) For the same spectral lines of the same order of the spectrum, the corresponding readings of the verniers are recorded on the other side of the direct image after adjusting the grating in the minimum deviation position. The difference in the readings of the same Vernier for the two positions (one left and another right of the direct image) gives twice the angle of minimum deviation. The mean value of D_m is calculated.

OBSERVATIONS:

Readings for the determination of D_m

Least Count of the spectrometer = Sec

OBSERVATION TABLE:

Order of the spectrum	Colour of the line	Vernier	Spectrum left of direct image			Spectrum right of direct image			Difference of the two readings of the same vernier (2Dm)	Mean ($\frac{D_m}{2}$)
			Main scale reading	Vernier reading	Total reading	Main scale reading	Vernier reading	Total reading		
1	Red	V ₁								
		V ₂								
	Yellow	V ₁								
		V ₂								
	Green	V ₁								
		V ₂								

RESULTS:

The wavelength of red line of the spectrum (correct to significant figures) given out of neon lamp = (..... ± maximum probable error) A.U.

The wavelength of yellow line of the spectrum (correct to significant figures) given out of neon lamp = (..... ± maximum probable error) A.U.

The wavelength of green line of the spectrum (correct to significant figures) given out of neon lamp = (..... \pm maximum probable error) A.U.

Superiority of Minimum deviation method over normal incidence method:

(i) It is easier to adjust the grating in the position of minimum deviation than in the case of normal incidence.

(ii) $(e+d) (\sin \theta + \sin i) = n\lambda$ or $\cos \theta \delta \theta + \cos i \delta i = 0 \therefore \delta \theta = -\cos i \sec \theta \cdot \delta i$
for normal incidence, $i = 0$ and $\cos i = 1$

Hence, $\delta \theta = -\sec \theta \delta i$

The grating cannot be set exactly with its surface normal to the incident beam and as such, an error δi in 'i' will cause a large error in the measurement of the angle of diffraction (hence, $\sec \theta > 1$). But a little departure of the grating from the minimum deviation position does not very much affect the measured angle of minimum deviation.

(iii) The spectrum obtained in the position of minimum deviation is very accurate.

PRECAUTIONS:

(i) The telescope must be so adjusted as to receive parallel rays and form a well-defined image of the slit on the crosswire.

(ii) The Grating table must be optically leveled.

(iii) The slit should be as narrow as possible and parallel to the ruled surface of the grating.

(iv) While handle the grating one should not touch its faces but hold it between the thumb and the fingers by edges only.

(v) While taking the observations of the spectral lines, the grating table must be clamped.

**PANDIT SUNDARLAL SHARMA (OPEN) UNIVERSITY
CHHATTISGARH, BILASPUR**



LABORATORY MANUAL

LASER DIFFRACTION AND INTERFERENCE

DR. POORAN SINGH CHOWDHARY

(M.Sc., Ph.D., LL.B.)

DEPARTMENT OF PHYSICS

***PANDIT SUNDARLAL SHARMA (OPEN) UNIVERSITY
CHHATTISGARH, BILASPUR***

OBJECT:

1. To determine the wavelength of laser light from a thin wire diffraction pattern.
2. Compare the thickness of the wire with the single-slit width that form the same diffraction pattern as wire and hence verify the Babinet's principle.
3. To explore the double-slit interference pattern.

APPARATUS:

Laser source (and safety goggles), screen & ruled-paper for recording, thin-wire source, variable single-slit and double-slit sources, grating, measuring tape, travelling microscope and (if available) digital camera.

THEORY:

When light passes through a small opening or around an edge, secondary waves from different portions of the emerging wavefront will, in general, travel different distances before reaching a screen. Although the waves from secondary sources are all in phase to start with, they will be out of phase by the time they reach the screen. The interference of these radiation emitted by secondary on the wavefront leads to the phenomenon of diffraction. We will study only Fraunhofer diffraction, where the light source, screen and the object causing diffraction are effectively at infinite distances from each other.

(A) Single-slit diffraction:

When a light of wavelength λ is incident normally on a narrow slit of width b , the resultant intensity of the transmitted light is given by,

$$I = I_0 \left[\frac{\sin^2 \beta}{\beta^2} \right], \text{ with } \beta = \frac{\pi b \sin \theta}{\lambda} \text{ ----- (1)}$$

where, θ being the angle of diffraction. The diffraction pattern consists of a principal maximum for $\beta = 0$, where all the secondary wavelets arrive in phase, and several secondary maxima of diminishing intensity with equally spaced points of zero intensity at $\beta = m\pi$. The positions of the minima of a single-slit diffraction pattern are, $m\lambda = b \sin \theta$, $m = \pm 1, \pm 2, \pm 3, \dots$ (2)

If θ is small i.e. the slit to screen distance D is large compared to the distance x_m between two m -th order minima (on either side of principal maximum), then

$$\sin \theta \approx \theta = x_m / 2D \Rightarrow m\lambda = b x_m / 2D \dots\dots\dots (3)$$

The above equation (3) can be used to determine the wavelength of the monochromatic light source, laser in present case, by measuring b , D and x_m for various m . The positions of the minima can be obtained by averaging the two extremities of the zero intensity regions, as shown in the picture below.

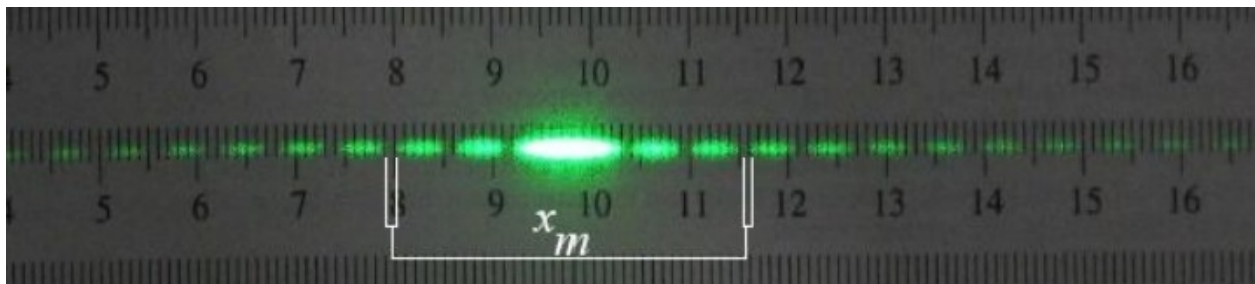

Figure 1. Single-slit diffraction pattern – distance between minima x_m is calculated from the average minima position on either side of principal maxima.

(B) Diffraction of a thin wire:

If the single-slit is replaced by a thin wire obstacle, which blocks as much laser light as a single-slit will allow passing, the resulting diffraction pattern will be identical to that of a single slit. Knowing the wavelength λ of the

laser light, the equation (3) can be used to determine the thickness of the wire b as,

$$b = 2m\lambda D / x_m \text{-----} (4)$$

A typical diffraction pattern of a wire obstacle is shown below. Here too, the positions of the minima are calculated by averaging the two ends of the spread of zero intensity regions as shown in Fig 2.

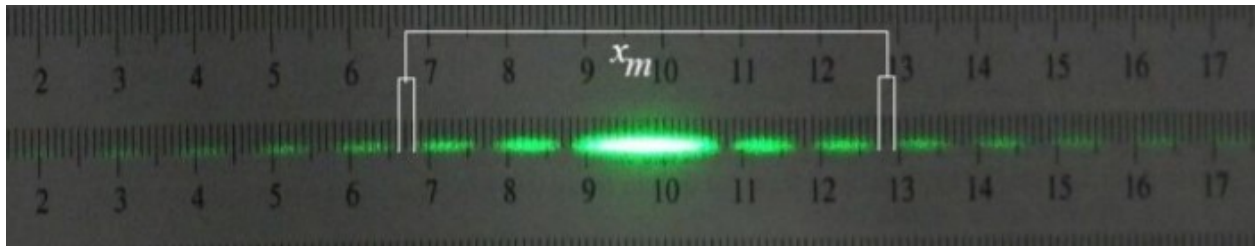

Figure 2. Diffraction pattern from wire obstacle– similarity with single-slit pattern is what Babinet’s principle asserts. x_m is measured as in single-slit case.

The fact that Fraunhofer diffraction pattern due to an obstacle is virtually identical to that of an opening of same dimension is an example of a general rule called Babinet’s principle. This principle can be verified by replacing once again the wire with a single- slit and varying the slitwidth until the pattern matches exactly. The slit width can then be compared with the wire thickness.

(C) Double-slit interference:

If instead of single-slit, we have two parallel slits each of width b separated by an opaque space of width c , the corresponding intensity distribution of the Fraunhofer pattern formed is,

$$I = I_0 [\text{Sin}^2 \beta / \beta^2] \cos^2 \gamma \text{-----} (5)$$

where θ being the angle of diffraction,

$$\beta = \pi b \sin \theta / \lambda, \gamma = \pi d \sin \theta / \lambda, d = b + c \text{ ----- (6)}$$

The intensity distribution is a product of two terms:

The first term $(\sin^2 \beta / \beta^2)$ represents diffraction pattern produced by single-slit (eqn.1) and the second term $\cos^2 \gamma$ is the characteristic of interference produced by two beams of equal intensity and phase difference γ . The overall pattern, therefore, consists of single-slit diffraction fringes each broken into narrow maxima and minima of interference fringes. This interference of light from two narrow slits close together was first demonstrated by Thomas Young in 1801 and helped establish the wave nature of light.

The minima for the interference fringes are at $\gamma = (2p + 1) \pi/2$ with

$p = 0, 1, 2, \dots$ and those for diffraction fringes are at

$\beta = m\pi$ where $m = 1, 2, 3, \dots$. The conditions for minima are,

$$d \sin \theta = (p + \frac{1}{2}) \lambda \text{ ----- (7)}$$

$$b \sin \theta = m \lambda \text{ ----- (8)}$$

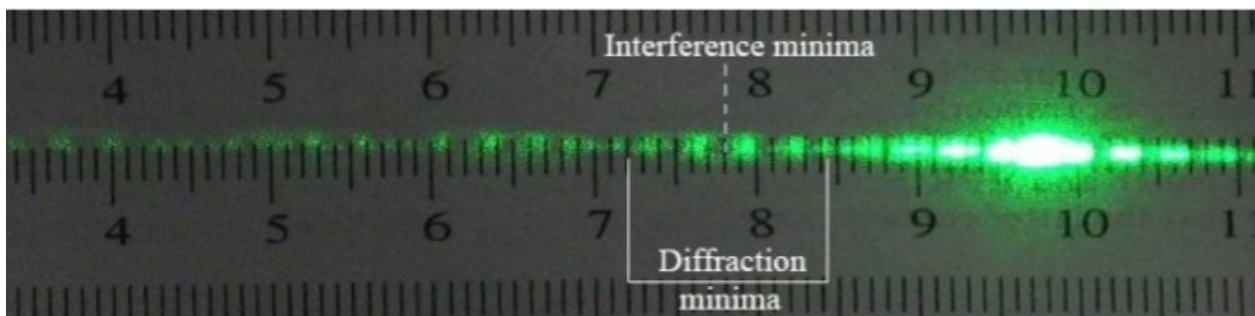

Figure 3. Double-slit interference pattern – each diffraction maxima is broken up into interference fringes. The minima positions x_p (interference) and x_m (diffraction) are read off directly without averaging.

A typical double-slit Fraunhofer pattern obtained with laser beam is shown in Fig 3. The intensity of laser may render viewing the pattern difficult without photographing.

PROCEDURE:

1. Determine the least count of the travelling microscope and measure the thickness b of the given wire.
2. Arrange the screen at least 3 meter away from the laser source. On the screen, attach a ruled paper with clips such that the ruled scale is horizontal. You may use graph paper in place of ruled-paper, if you consider it convenient.
3. Turn the laser on and be extremely careful not to let your eyes in the direct or reflected line of the laser. Do not turn the laser off and on too frequently, instead uses something to block the laser when it is not in use.
4. Adjust the height of the laser (and also the screen) such that the laser spot is directly on the ruled line in the middle of the paper.
5. To record the pattern that will be produced on the screen, mark the fringe pattern with pencil on edges of bright spots on both left and right side of the central maximum. Calculate the midpoints of minima and subtract one from other to find $x_m = f_m^l \sim f_m^r$
6. First place a thin wire apparatus close in front of the laser and observe the diffraction pattern on the screen. Adjust the laser and slit so as to obtain a bright, crisp pattern. Measure the slit to the screen distance D with a measuring tape. Calculate the wavelength of the laser in use from the data and equation (3) by straight line fit.
7. Next replace the wire with a single slit and adjust the width of the slit to match the pattern which was obtained with the wire. Keep the distance

RESULT:

Observed wavelength of the Laser light is (λ_0): nm

Actual wavelength (λ_A): 589.3 nm

% error: $[(\lambda_0 - \lambda_A) / \lambda_A] \times 100 = \%$.

PRECAUTIONS:

1. The slit should be parallel to the wire.
2. The screen should be in perfectly stable positions when reading is being taken.
3. The grating must be held horizontally in the clamp.
4. The wire must be kept straight between the two clamps.
5. The laser light must be incident right in the center of the grating.
6. The laser should not be kept on for a long time.

**PANDIT SUNDARLAL SHARMA (OPEN) UNIVERSITY
CHHATTISGARH, BILASPUR**



LABORATORY MANUAL

TO DETERMINE THE WAVELENGTH OF SODIUM LIGHT

BY

NEWTON'S RING METHOD

DR. POORAN SINGH CHOWDHARY

(M.Sc., Ph.D., LL.B.)

DEPARTMENT OF PHYSICS

***PANDIT SUNDARLAL SHARMA (OPEN) UNIVERSITY
CHHATTISGARH, BILASPUR***

OBJECT: To determine the wavelength of sodium light by Newton's Ring method.

Apparatus: A nearly monochromatic source of light (source of sodium light), a Plano-convex lens, an optically plane glass plate, an optically flat glass plate inclined at an angle of 45° , a travelling microscope with measuring scale and a spectrometer.



THEORY:

(A) Condition for formation of bright and dark fringes:

When a parallel beam of monochromatic light is incident normally on a combination of a Plano-convex lens C and a glass plate P, as shown in Figure 1 (a), a part of each incident ray is reflected from the lower surface of the lens, and a part, after refraction through the film between the lens and the plate, is reflected back from the surface of glass plate. These two reflected rays are coherent; hence they will interfere and produce a system of alternate dark and bright rings Figure 1 (b) with the point of contact between the lens and the plate at the center. These rings are known as Newton's rings.

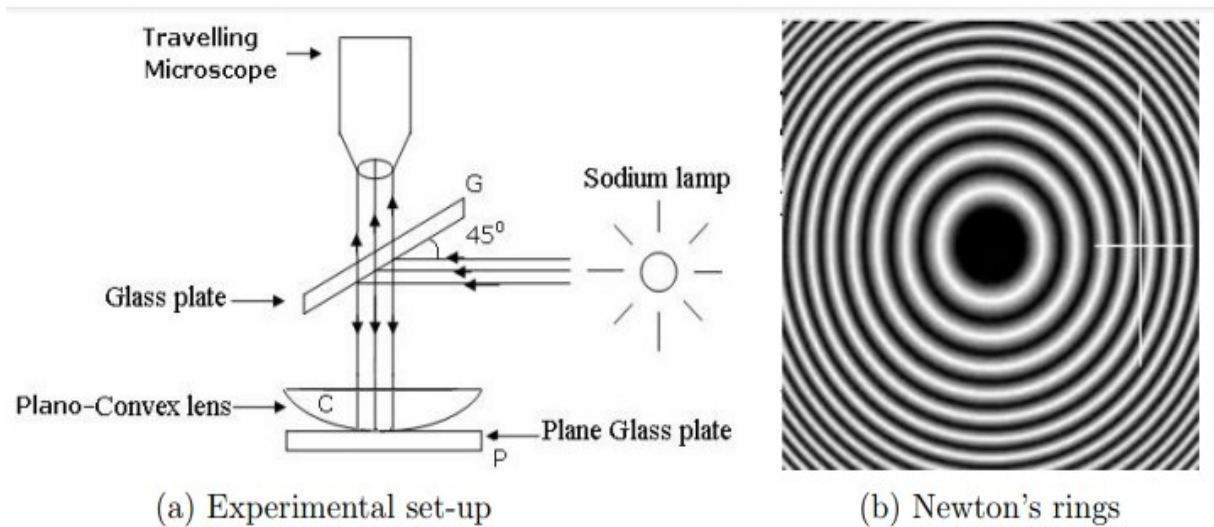

Figure 1

In general, the path difference between the reflected light beams which are undergoing interference (for oblique incidence) is given by

$$\Delta = 2\mu t \cos\theta - \lambda / 2 \text{ ----- (1)}$$

where additional path difference of $\lambda / 2$ is because one of the interfering beam is reflected from film to glass surface. Also, θ is the angle of incidence. For normal incidence $\theta = 0^\circ$ and hence, the path difference will be

$$\Delta = 2\mu t - \lambda / 2 \text{ ----- (2)}$$

In the interference pattern bright fringe will be formed if the path difference is equal to integral multiple of wavelength of light, i.e.,

$$\Delta = 2\mu t - \lambda / 2 = n\lambda; n = 0, 1, 2, 3...$$

$$\Rightarrow 2\mu t = (n + 1/2) \lambda; n = 0, 1, 2, 3 \text{ ----- (3)}$$

For intensity minima (dark fringe), $\Delta = (n + 1/2) \lambda$, and thus,

$$2\mu t = n\lambda; n = 0, 1, 2, 3 \text{ ----- (4)}$$

(B) Relationship between ring diameter and wavelength:

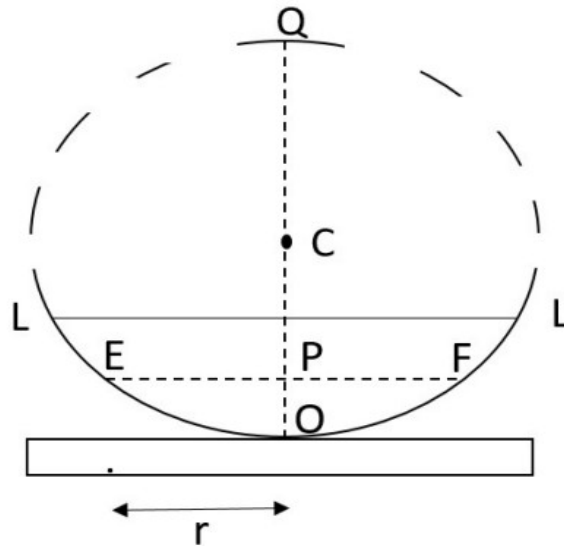

Figure 2

In Figure 2, let LOL' is the Plano-convex lens placed on glass plate. Plano-convex lens appears as part of circle of radius R. Here, radius R is known as radius of curvature of Plano-convex lens. Suppose r is the radius of some nth bright ring having thickness t, using the property of circle, from Figure 2, we can write

$$EP \times PF = PO \times PQ \Rightarrow r_n^2 = t \times (2R - t) \Rightarrow r_n^2 = (2Rt - t^2).$$

Since $R \gg t$, t^2 can be neglected therefore

$$r_n^2 = 2Rt \text{ ----- (5)}$$

By using Eq. (4) and Eq. (5), we have

$$r_n^2 = n\lambda R / \mu \text{ ----- (6)}$$

Using $r_n = D_n/2$, we can write following relation for diameter of nth ring

$$D_n^2 = 2 r_n^2 = n\lambda R / \mu \text{ ----- (7)}$$

The diameter of some m^{th} dark fringe will be

$$D_m^2 = m\lambda R / \mu \text{ ----- (8)}$$

Subtracting Eq. (7) and Eq. (8), we can write following relation

$$\lambda = [(D_n^2 - D_m^2) \mu] / [4R (n - m)] \text{ ----- (9)}$$

Above equation is used to find the wavelength of monochromatic light using Newton ring's method, in which material of refractive index μ is immersed between Plano-convex lens and glass plate.

If air is enclosed as thin film having $\mu=1$, then Eq. (9) becomes

$$\lambda = (D_n^2 - D_m^2) / [4R (n - m)] \text{ ----- (10)}$$

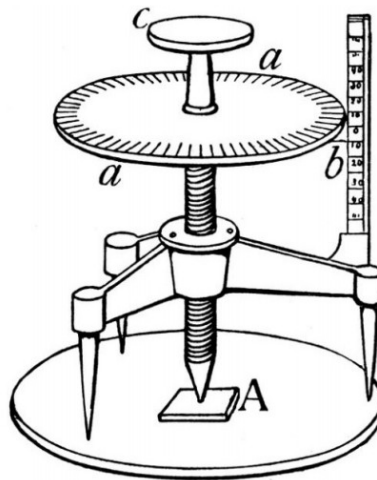

Figure 3

The radius of curvature, R is calculated by spherometer (Figure 3) using following relation

$$R = l^2 / 6h + h / 2 \text{ ----- (11)}$$

In above, l is the mean length of the three sides of equilateral triangle formed by joining the tips of three outer legs and h represents the height of the central screw above or below the plane of the outer legs.

PROCEDURE: The experimental set-up used for the experiment is shown in Figure 1 (a).

1. Level the travelling microscope table and set the microscope tube in a vertical position. Find the vernier constant (least count) of the horizontal scale of the travelling microscope.

2. Clean the surface of the inclined glass plate G, the lens C and the glass plate P. Place those in position as shown in Figure 1 (a) and as discussed in the description of apparatus. Place the arrangement in front of a sodium lamp so that the height of the center of the glass plate G is the same as that of the center of the sodium lamp. (Figure 3, Spherometer).

3. Adjust the position of the travelling microscope so that it lays vertically above the center of lens C. Focus the microscope, so that alternate dark and bright rings are clearly visible.

4. Adjust the position of the travelling microscope till the point of intersection of the cross wires (attached in the microscope eyepiece) coincides with the center of the ring system.

5. Slide the microscope to the left till the cross wire lies tangentially at the center of the 20th dark ring. Note the reading on the vernier scale of the microscope. Slide the microscope backward with the help of the slow motion screw and note the readings when the cross-wire lays tangentially at the center (Figure 1 (b)) of the 18th, 16th, 14th, 12th, 10th, 8th, 6th, and 4th dark rings, respectively. [Observations of first few rings from the center are generally not taken because it is difficult to adjust the cross-wire in the middle of these rings owing to their large width.]

6. Keep on sliding the microscope to the right and note the reading when the crosswire again lays tangentially at the center of the 4th, 6th, 8th, 10th, 12th, 14th, 16th, 18th, and 20th dark rings, respectively.

7. Remove the Plano-convex lens C and find the radius of curvature of the surface of the lens in contact with the glass plate P accurately using a spherometer.

8. Find the diameter of the each ring from the difference of the observations taken on the left and right side of its center.

9. Take any two diameters and perform the calculations for $D_n^2 - D_m^2$ ($m < n$) as directed in table 1

10. Finally calculate the value of wavelength of the sodium light source using Eq. (9).

OBSERVATIONS:

(A) Diameter



Figure 4: Vernier Scale of the Microscope

1. M.S.D =

2. V.S.D =

3. Vernier constant = . . . cm.

4. μ (air) =

Sr. no.	Ring no. (n)	Microscope reading (cm)						$D_n = L - R$ (cm)	D_n^2 (cm ²)	$D_n^2 - D_m^2$ (cm ²)
		Left(L)			Right(R)					
		Main	Vernier	Total	Main	Vernier	Total			
1										
2										
3										
4										
5										
6										
7										
8										
9										
10										

Table 1: Measurements of the diameter of the ring.

(B) Spherometer:

1. Pitch of the screw = cm
2. Number of divisions on circular head =
3. Least count of the spherometer = cm

Sr. no.	Spherometer readings on		h (cm)	l (cm)
	convex surface	plane surface		
1.				
2.				
3.				

Table 2: Calculations of h and l .

4. The mean height h of the central screw = cm and the mean distance between the two legs of the spherometer, l = cm

5. The radius of curvature R = cm

(C) Wavelength:

Sr. No.	$\lambda = [(D_n^2 - D_m^2) \mu] / [4R (n - m)]$
01	
02	
03	
04	
05	
06	
07	

Table 3: Calculations for wavelength λ

The mean wavelength (λ) of Sodium light is = nm

RESULT:

Observed wavelength of the Sodium light is (λ_0): nm

Actual wavelength (λ_A): 589.3 nm

% error: $[(\lambda_0 - \lambda_A) / \lambda_A] \times 100 = \%$.

PRECAUTIONS: Notice that as you go away from the central dark spot the fringe width decreases. In order to minimize the errors in measurement of the diameter of the rings the following precautions should be taken:

1. The microscope should be parallel to the edge of the glass plate.
2. The mirrors should be in perfectly stable positions when reading is being taken.
3. There should be no play between the screw and the nut in which it rotates.
4. To avoid any backlash error, the micrometer screw of the travelling microscope should be moved very slowly and be moved in one direction while taking observations.
5. While measuring diameters, the microscope cross-wire should be adjusted in the middle of the ring (Figure 1 (b)).

VERIFIED



Dr. Anita Singh
Incharge NAAC Criteria-1
PSSOU, CG Bilaspur

**PANDIT SUNDARLAL SHARMA (OPEN) UNIVERSITY CHHATTISGARH
BILASPUR**



LABORATORY MANUAL

Bachelor of Science

Physics

(B.Sc. IIIrd Year)

Department of Physics

PANDIT SUNDARLAL SHARMA (OPEN) UNIVERSITY CHHATTISGARH, BILASPUR

VERIFIED

REGISTRAR
Pt. Sunderlal Sharma (Open)
University Chhattisgarh
BILASPUR (C.G.)

Dr. Anita Singh
Incharge NAAC Criteria-I
P53911, CG Bilaspur

**PANDIT SUNDARLAL SHARMA (OPEN) UNIVERSITY
CHHATTISGARH, BILASPUR**



LABORATORY MANUAL

THEORY OF THE TUNNEL DIODE

DR. POORAN SINGH CHOWDHARY

(M.Sc., Ph.D., LL.B.)

DEPARTMENT OF PHYSICS

***PANDIT SUNDARLAL SHARMA (OPEN) UNIVERSITY
CHHATTISGARH, BILASPUR***

TUNNEL DIODE:

A Tunnel diode is a heavily doped p-n junction diode which displays a negative resistance behavior in a specific region in its characteristic curve. By Negative resistance we mean that in that region, the current flowing through the diode decreases as the voltage is increased. As the voltage is increased from zero, the current through the diode increases, then it decreases, and then it again increases. The initial increase of current (before its decrease) is attributed to a phenomenon called Quantum Tunneling. This is the reason for the particular name of this device. The tunnel diode is used as a fast switching device in computers as well as in high frequency oscillators and amplifiers.

Symbol of tunnel diode:

The symbol for Tunnel Diode is shown in the figure below.



An anode is a positively charged electrode that attracts electrons. The Cathode is a negatively charged electrode that emits electrons. In a tunnel diode, the anode is connected to p-type semiconductor while the cathode is connected to n-type semiconductor.

What is a Tunnel Diode?

The Tunnel diode was invented by Leo Esaki in 1958. This is why it is also known as Esaki diode. Esaki observed that if a semiconductor is heavily doped with impurities, it exhibits a negative dynamic resistance. This means that the current through the device decreases as the voltage across it is

increased. Leo Esaki got the Nobel Prize in 1973 for discovering the quantum tunneling effect causes this behavior in these diodes. Quantum tunneling refers to a direct flow of electrons across a thin depletion region from the n-side conduction band to the p-side valence band. Tunnel Diodes are generally constructed from Germanium. But they are also made from other types of materials such as gallium arsenide, gallium antimonite, and silicon.

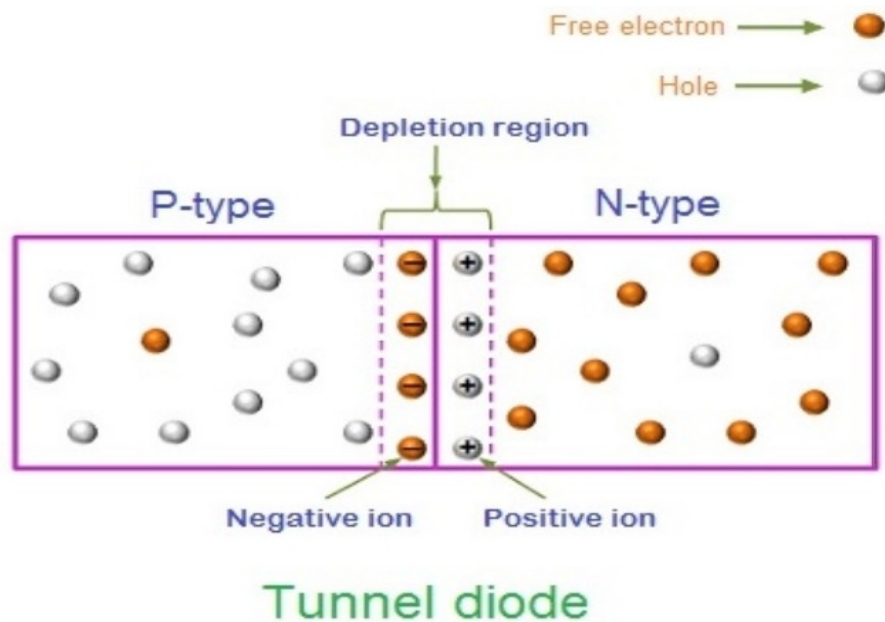

Width of the depletion region in tunnel diode:

The depletion region is a region that exists on both sides of a p-n junction which is devoid of mobile charge carriers (Free electrons and Holes). This region acts as a potential barrier that opposes the flow of electrons from the n-side to p-side and of holes from the p-side to n-side. Only those very few charge carriers whose kinetic energy is more than the barrier height can cross the depletion region.

The width of the depletion region depends on the concentration of the impurity atoms. We call those specific atoms as impurities which have been introduced into the semiconductor in a very small amount to give them the

characteristic properties that make them either p-type or n-type. If only a small number of impurity atoms are present, both on the n-side and the p-side (This is known as light doping) of the p-n junction diode, a wide depletion region is formed. On the other hand, if large number of impurities is added during the construction of the p-n junction diode, a narrow depletion region is formed.

In a Tunnel diode, the p-type and n-type semiconductors that form the junction are both heavily doped. This means that there is a very large concentration of impurity atoms on both sides of the p-n junction. The concentration of impurities in tunnel diode is nearly a thousand times greater than that in the normal p-n junction diode. This heavy doping produces an extremely narrow depletion region.

Forward biased normal p-n junction diode:

In a normal p-n junction diode, the width of the depletion region is large as compared to the width of depletion region the tunnel diode. This wide depletion layer in the normal diode opposes the flow of current. Hence, depletion layer acts as a barrier. To overcome this barrier, we need to apply sufficient voltage. When sufficient voltage is applied electric current starts flowing through the diode.

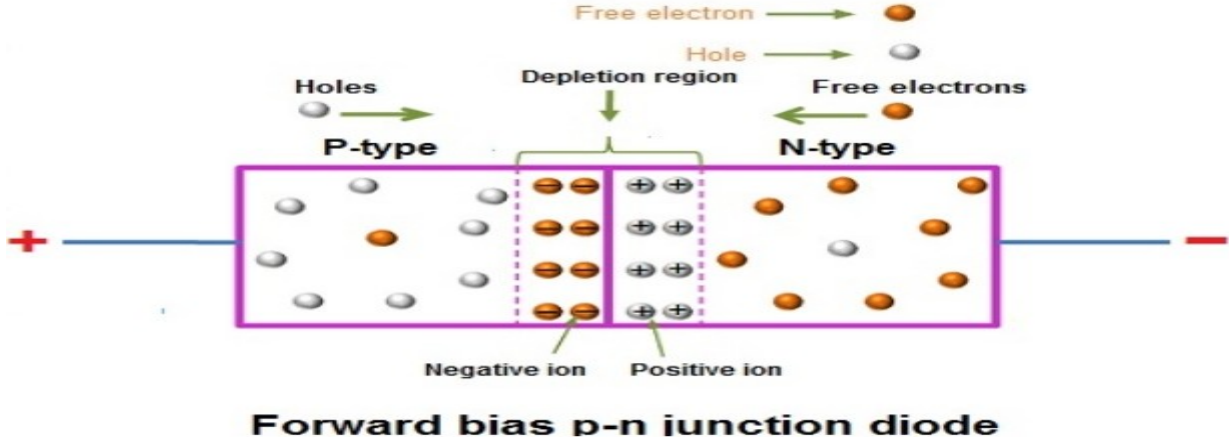

Forward biased tunnel diode:

Unlike the normal p-n junction diode, the width of a depletion layer in tunnel diode is extremely narrow. So applying a small voltage is enough to produce electric current due to the quantum tunneling effect. Quantum tunneling is explained below. Tunnel diodes are capable of remaining stable for a long duration of time than the ordinary p-n junction diodes. They are also capable of high-speed operations.

Concept of tunneling:

The depletion region in a p-n junction diode contains positive and negative ions embedded in the crystal lattice. These positive and negative ions create a potential gradient or electric field in the depletion region. This electric field exerts an electric force in a direction opposite to the externally applied electric field that is produced due to biasing. Now, energy levels of the valence band and conduction band in the n-type semiconductor are slightly lower than corresponding energy levels in the p-type semiconductor. This is because trivalent impurities exert lower forces on the outer-shell electrons and lower forces mean that the electron orbits are slightly larger and have greater energy.

When a forward bias voltage is applied to the ordinary p-n junction diode, the width of depletion region decreases and at the same time the barrier height also decreases. However, the electrons in the n-type semiconductor cannot penetrate through the depletion layer because the built-in voltage of depletion layer opposes the flow of electrons. If the applied voltage is greater than the built-in voltage of depletion layer, the electrons from n-side overcome the opposing force from depletion layer and they enter into p-side. In simple words, the electrons can pass over the barrier (depletion layer) if the energy of the electrons is greater than the barrier height or barrier potential. Therefore, an ordinary p-n junction diode produces

electric current only if the applied voltage is greater than the built-in voltage of the depletion region.

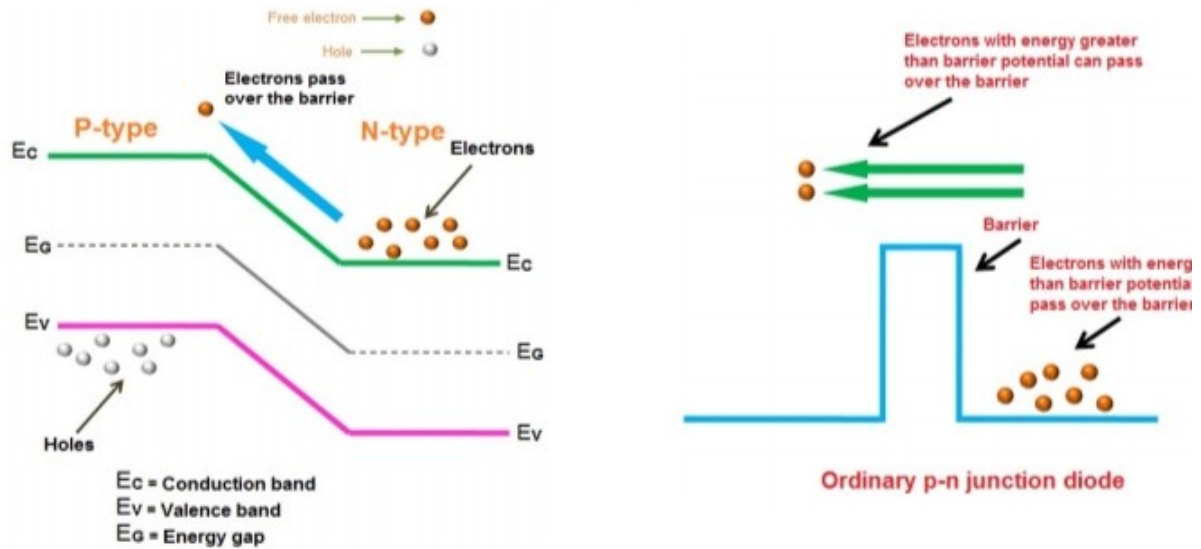

Electric current in a p-n junction diode:

When a forward bias voltage is applied to the ordinary p-n junction diode the width of depletion region decreases and at the same time the barrier height also decreases. However, the electrons in the n-type semiconductor cannot penetrate through the depletion layer because the built-in voltage of depletion layer opposes the flow of electrons. If the applied voltage is greater than the built-in voltage of depletion layer, the electrons from n-side overcome the opposing force from depletion layer and they enter into p-side. In simple words, the electrons can pass over the barrier (depletion layer) if the energy of the electrons is greater than the barrier height or barrier potential. Therefore, an ordinary p-n junction diode produces electric current only if the applied voltage is greater than the built-in voltage of the depletion region.

Electric current in a tunnel diode:

In tunnel diode, the valence band and conduction band energy levels in the n-type semiconductor are lower than the corresponding levels in the p-type semiconductor. Unlike the ordinary p-n junction diode, the difference in energy levels is very high in tunnel diode. Because of this high difference, the conduction band of the n-type material overlaps with the valence band of the p-type material. According to Quantum mechanics, the electrons directly penetrate through the depletion layer or barrier if the depletion width is very small. The depletion layer of tunnel diode is very small. It is in nanometers. So the electrons can directly tunnel across it from n-side conduction band into the p-side valence band. In ordinary diodes, current is produced when the applied voltage is greater than the built-in voltage of the depletion region. But in tunnel diodes, a small voltage which is less than the built-in voltage of depletion region is enough to produce electric current. In tunnel diodes, the electrons need not overcome the opposing force from the depletion layer to produce electric current. The electrons can directly tunnel from the conduction band of n-region into the valence band of p-region. Thus, electric current is produced in tunnel diode.

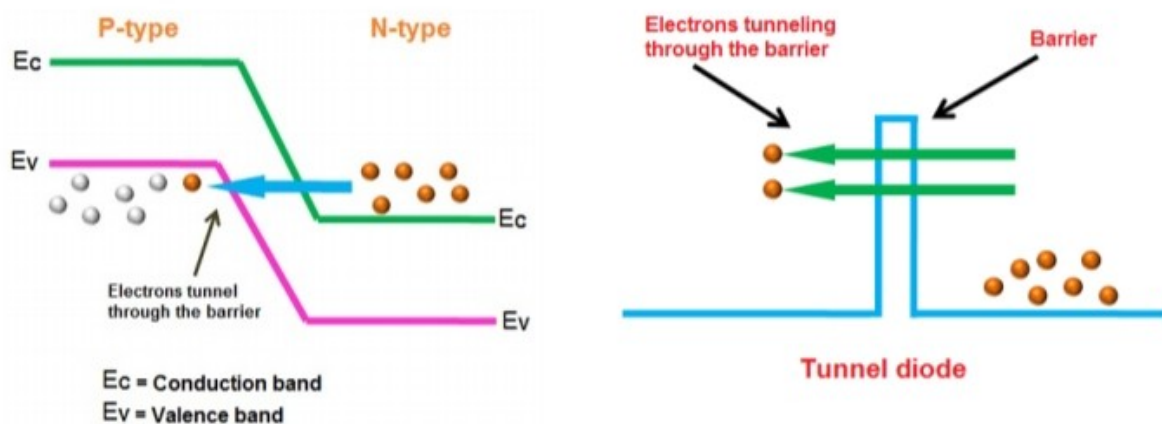

Tunnel Diode Characteristics:

Step 1: Unbiased tunnel diode

When no voltage is applied to the tunnel diode, it is said to be an unbiased tunnel diode. In tunnel diode, the conduction band of the n-type material overlaps with the valence band of the p-type material because of the heavy doping. Because of this overlapping, the conduction band electrons at n-side and valence band holes at p-side are nearly at the same energy level. So when the temperature increases, some electrons tunnel from the conduction band of n-region to the valence band of p-region. In a similar way, holes tunnel from the valence band of p-region to the conduction band of n-region. The net current flow is zero because an equal number of charge carriers (free electrons and holes) flow in opposite directions.

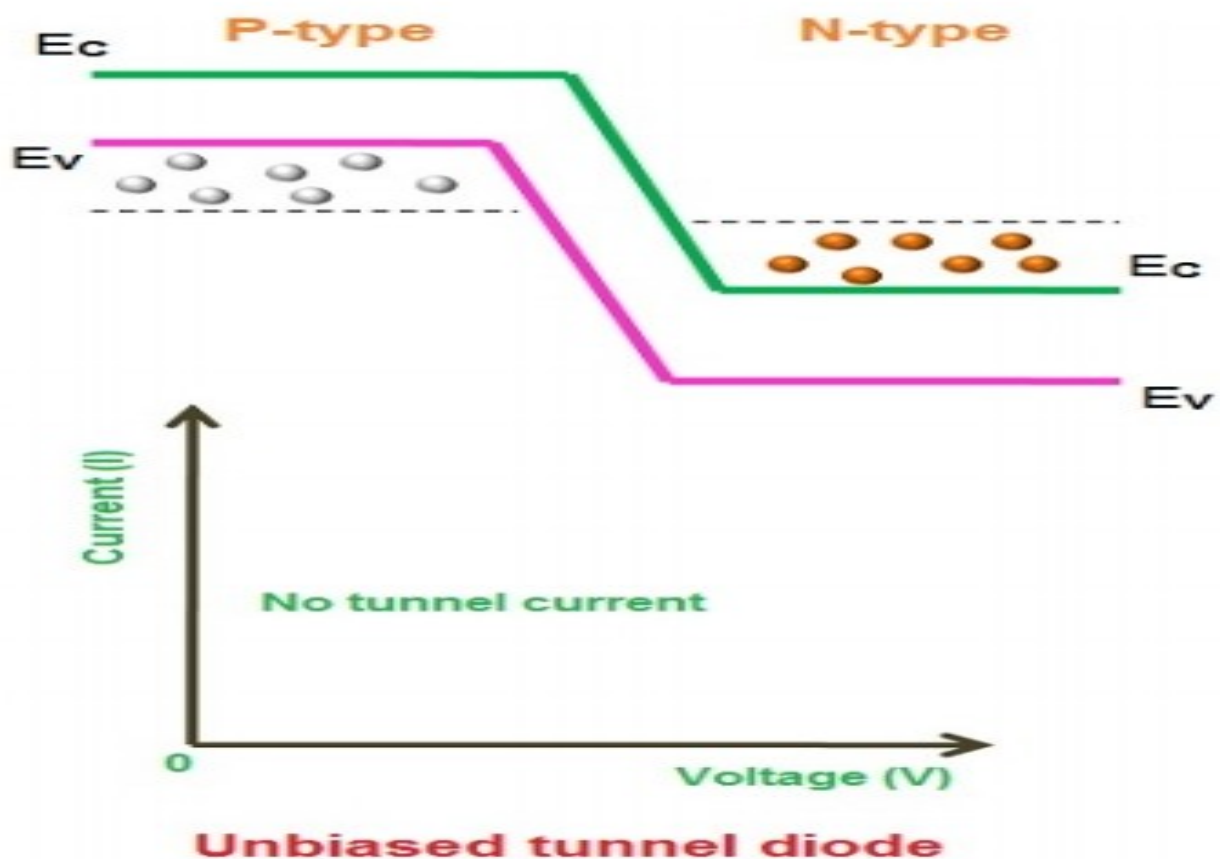

Step 2: Small voltage applied to the tunnel diode

When a small voltage is applied to the tunnel diode which is less than the built-in voltage of the depletion layer, no forward current flows through the junction. However, a small number of electrons in the conduction band of the n-region will tunnel to the empty states of the valence band in p-region. This will create a small forward bias tunnel current. Thus, tunnel current starts flowing with a small application of voltage.

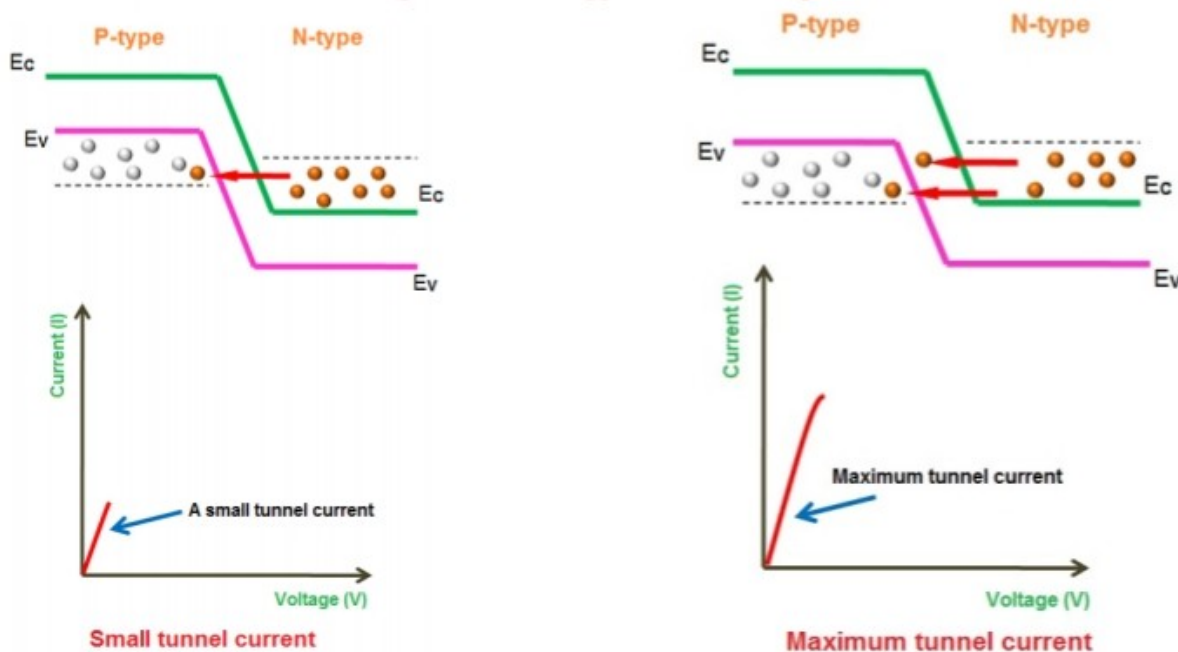

Step 3: Applied voltage is slightly increased

When the voltage applied to the tunnel diode is slightly increased, a large number of free electrons at n-side and holes at p-side are generated. Because of the increase in voltage, the overlapping of the conduction band and valence band is increased. In simple words, the energy level of an n-side conduction band becomes exactly equal to the energy level of a p-side valence band. As a result, maximum tunnel current flows.

Step 4: Applied voltage is further increased

Applied voltage is further increased. If the applied voltage is further increased, a slight misalignment of the conduction band and valence band takes place. Since the conduction band of the n-type material and the valence band of the p-type material still overlap, the electrons tunnel from the conduction band of the n-region to the valence band of the p-region and cause a small current flow. Thus, the tunneling current starts decreasing.

Step 5: Applied voltage is largely increased

If the applied voltage is largely increased, the tunneling current drops to zero. At this point, the conduction band and valence band no longer overlap and the tunnel diode operates in the same manner as a normal p-n junction diode. If this applied voltage is greater than the built-in potential of the depletion layer, the regular forward current starts flowing through the tunnel diode.

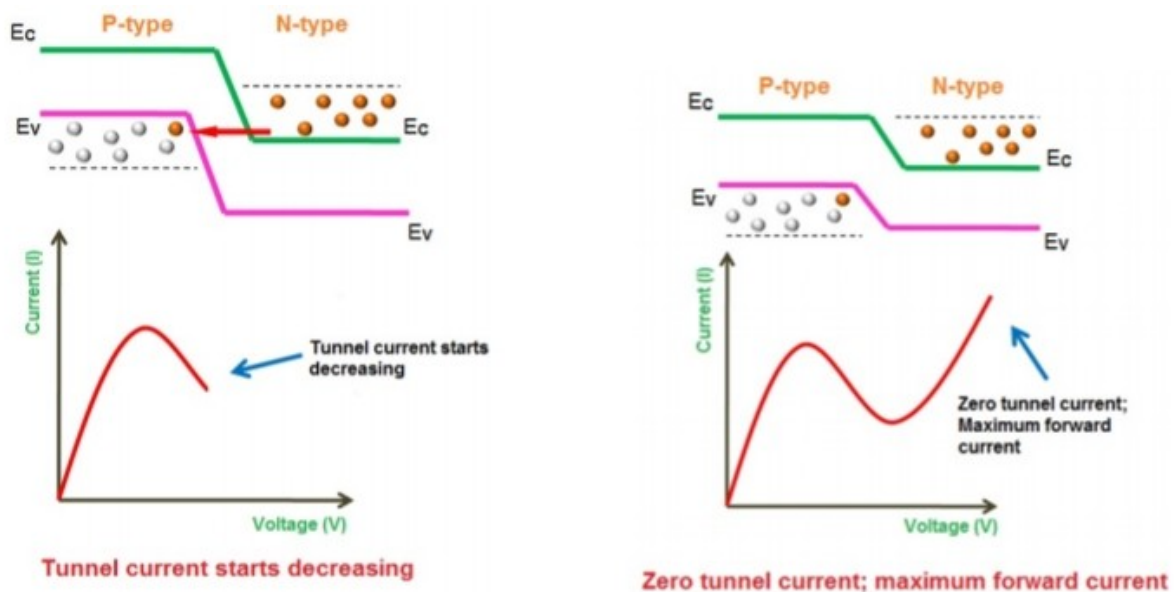

The portion of the curve in which current decreases as the voltage increases is the negative resistance region of the tunnel diode. The negative resistance region is the most important and most widely used characteristic

of the tunnel diode. A tunnel diode operating in the negative resistance region can be used as an amplifier or an oscillator.

Advantages of tunnel diodes:

Tunnel diodes have the following advantageous features.

1. Long life
2. High-speed operation
3. Low noise
4. Low power consumption

Disadvantages of tunnel diodes:

1. Tunnel diodes cannot be fabricated in large numbers
2. Being a two terminal device, the input and output are not isolated from one another.

Applications of tunnel diodes:

1. Tunnel diodes are used as logic memory storage devices.
2. Tunnel diodes are used in relaxation oscillator circuits.
3. Tunnel diode is used as an ultra high-speed switch.
4. Tunnel diodes are used in FM receivers.

**PANDIT SUNDARLAL SHARMA (OPEN) UNIVERSITY
CHHATTISGARH, BILASPUR**



LABORATORY MANUAL

OBSERVATION OF CHARACTERISTICS OF A ZENER DIODE

DR. POORAN SINGH CHOWDHARY

(M.Sc., Ph.D., LL.B.)

DEPARTMENT OF PHYSICS

***PANDIT SUNDARLAL SHARMA (OPEN) UNIVERSITY
CHHATTISGARH, BILASPUR***

OBJECT:

In this experiment, we try to observe the relation between the voltage and corresponding current generated. We will then plot it to get the dependence.

APPARATUS REQUIRED:

Zener diode, DC voltage supplier, Bread board, 100Ω resistor, 2 multi meters for measuring current and voltage and Connecting wires.

THEORY:

A Zener Diode is constructed for operation in the reverse breakdown region. The relation between I-V is almost linear in this case $V_z = V_{z0} + I_z r_z$ where r_z is the dynamic resistance of the zener at the operating point. V_{z0} is the voltage at which the straight-line approximation of the I-V characteristic intersects the horizontal axis. After reaching a certain voltage, called the breakdown voltage, the current increases widely even for a small change in voltage. However, there is no appreciable change in voltage. So, when we plot the graph, we should get a curve very near to x-axis and almost parallel to it for quite some time. After the Zener potential V_z there will be a sudden change and the graph will become exponential.

PROCEDURE:

We first construct the circuit as shown in the figure with the 100Ω resistance and a variable DC input voltage. Now, we start increasing the voltage till there is some reading in the multi meter for current. Then, we note that reading. Now, we start increasing the input voltage and take the corresponding current readings. We get a set of values and construct V versus I graph. This graph gives us the I-V characteristics. The slope of the curve at any point gives the dynamic resistance at that voltage.

CIRCUIT DIAGRAM:

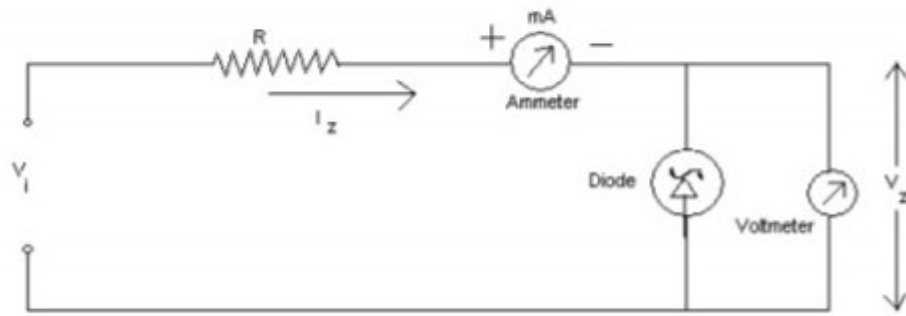

V_i = Input voltage

R = 100 ohms resistance

I_z = Current across zener diode

V_z = Output drop across zener diode

OBSERVATION TABLE:

Least count of voltmeter:

Least count of ammeter

Measurement of V and I in reverse bias:

S. No.	Voltage (V)	Current (mA)
01		
02		
03		
04		
05		
06		
07		
08		
09		

On plotting V_z versus I_z graph, we get the following pattern:

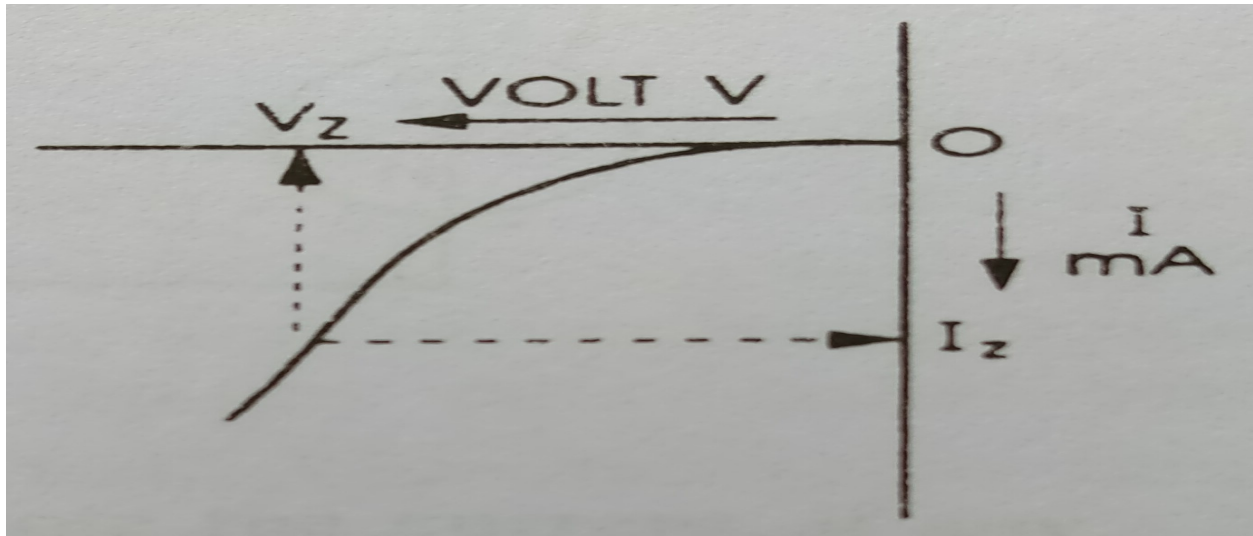

RESULT:

The breakdown potential, also called the zener potential i.e. $V_z \approx \text{----- V}$

PRECAUTIONS:

1. The two terminals of the zener must be fully identified.
2. Practically zener contains two terminals, which are called p terminal and n terminal.
3. Zener diode should always be used in reverse bias.
4. Voltage exceeding the limit should not be applied.

DISCUSSIONS:

The precautions are quite similar to that taken in a normal diode i.e. Excessive flow of current may damage the diode

Current for sufficiently long time may change the characteristics

Zener diodes are used in voltage regulation in circuits because even when, a large current flows through, their voltage does not change appreciably.

**PANDIT SUNDARLAL SHARMA (OPEN) UNIVERSITY
CHHATTISGARH, BILASPUR**



LABORATORY MANUAL

CHARACTERISTICS OF TRANSISTOR IN CE CONFIGURATION

DR. POORAN SINGH CHOWDHARY

(M.Sc., Ph.D., LL.B.)

DEPARTMENT OF PHYSICS

***PANDIT SUNDARLAL SHARMA (OPEN) UNIVERSITY
CHHATTISGARH, BILASPUR***

AIM:

To draw the input and output characteristics of transistor connected in CE configuration.

APPARATUS: Transistor (SL100 or BC107), R.P.S (0-30V) 2 numbers, Voltmeters (0-20V) 2 numbers, Ammeters (0-200mA), Resistors 100K ohm, 100 ohm, Bread board and connecting wires.

THEORY:

A transistor is a three terminal device. The terminals are emitter, base, collector. In common emitter configuration, input voltage is applied between base and emitter terminals and output is taken across the collector and emitter terminals. Therefore the emitter terminal is common to both input and output. The input characteristics resemble that of a forward biased diode curve.

This is expected since the Base-Emitter junction of the transistor is forward biased. As compared to CB arrangement I_B increases less rapidly with V_{BE} . Therefore input resistance of CE circuit is higher than that of CB circuit.

The output characteristics are drawn between I_C and V_{CE} at constant I_B the collector current varies with V_{CE} upto few volts only. After this the collector current becomes almost constant, and independent of V_{CE} .

The value of V_{CE} up to which the collector current changes with V_{CE} is known as Knee voltage.

The transistor always operated in the region above Knee voltage, I_C is always constant and is approximately equal to I_B .

The current amplification factor of CE configuration is given by $\beta = \Delta I_C / \Delta I_B$

CIRCUIT DIAGRAM:

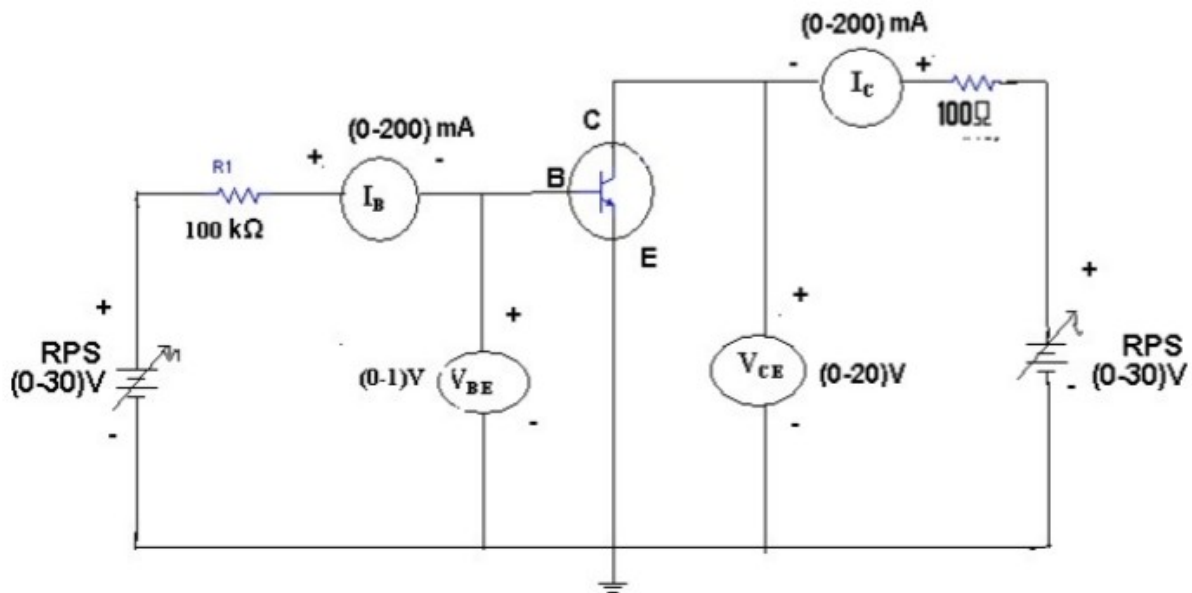

PROCEDURE:

(A) INPUT CHARACTERISTICS:

1. Connect the circuit as per the circuit diagram.
2. For plotting the input characteristics the output voltage V_{CE} is kept constant at 1V and for different values of V_{BE} . Note down the values of I_C .
3. Repeat the above step by keeping V_{CE} at 2V and 4V.
4. Tabulate all the readings.
5. Plot the graph between V_{BE} and I_B for constant V_{CE} .

(B) OUTPUT CHARACTERISTICS:

1. Connect the circuit as per the circuit diagram.
2. For plotting the output characteristics the input current I_B is kept constant at 10 μ A and for different values of V_{CE} note down the values of I_C .

3. Repeat the above step by keeping I_B at 75 μA 100 μA Electronics Laboratory

4. Tabulate the all the readings.

5. Plot the graph between V_{CE} and I_C for constant I_B .

OBSERVATION TABLES:

(A) INPUT CHARACTERISTICS:

Least count of voltmeter=

Least count of micro ammeter=

S. No.	$V_{CE} = 1 V$		$V_{CE} = 2 V$		$V_{CE} = 3 V$	
	$V_{BE} (V)$	$I_B (\mu A)$	$V_{BE} (V)$	$I_B (\mu A)$	$V_{BE} (V)$	$I_B (\mu A)$
01						
02						
03						
04						

(B) OUT PUT CHAREACTARISTICS:

Least count of voltmeter=

Least count of mili ammeter=

Least count of micro ammeter=

S. No.	$I_B = 50 \mu A$		$I_B = 75 \mu A$		$I_B = 100 \mu A$	
	$V_{CE} (V)$	$I_C (\mu A)$	$V_{CE} (V)$	$I_C (\mu A)$	$V_{CE} (V)$	$I_C (\mu A)$
01						
02						
03						
04						

MODEL GRAPHS:

(A) INPUT CHARACTERISTICS:

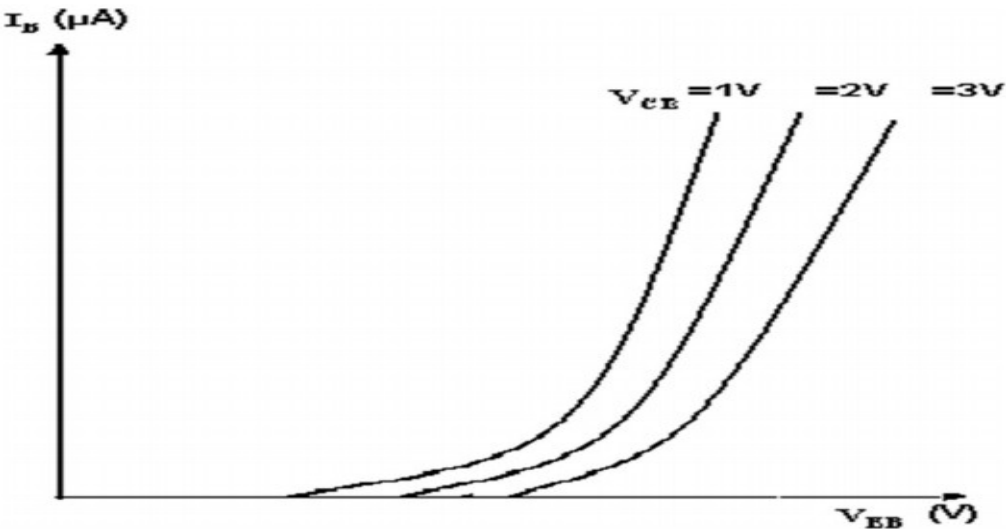

(B) OUTPUT CHARACTERISTICS:

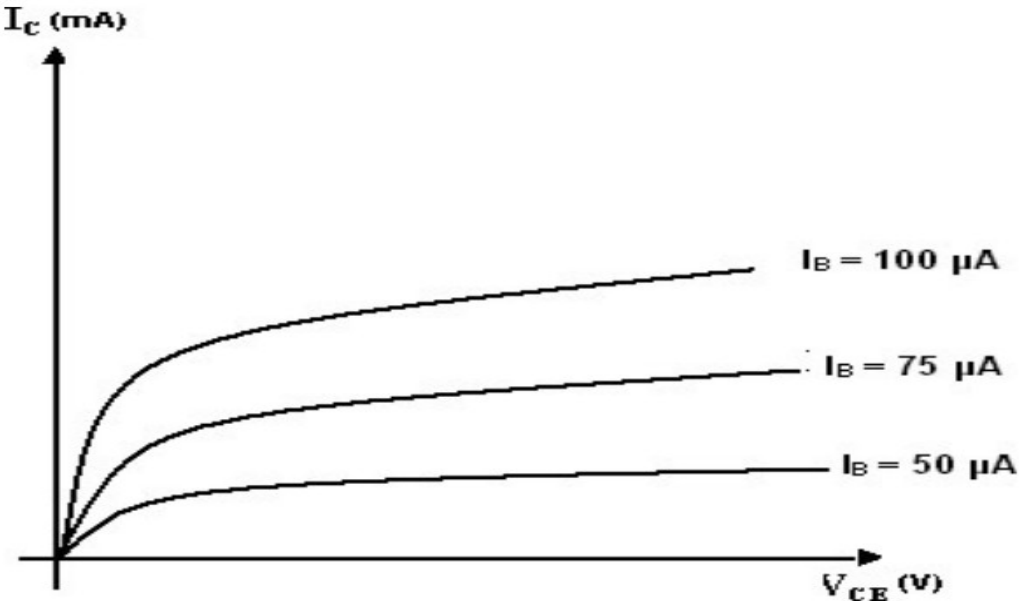

PRECAUTIONS:

1. The supply voltage should not exceed the rating of the transistor.
2. Meters should be connected properly according to their polarities.

VIVA QUESTIONS:

1. What is the range of β for the transistor?
2. What are the input and output impedances of CE configuration?
3. Identify various regions in the output characteristics?
4. What is the relation between α and β .
5. Define current gain in CE configuration?
6. Why CE configuration is preferred for amplification?
7. What is the phase relation between input and output?
8. Draw diagram of CE configuration for PNP transistor?
9. What is the power gain of CE configuration?
10. What are the applications of CE configuration?

**PANDIT SUNDARLAL SHARMA (OPEN) UNIVERSITY
CHHATTISGARH, BILASPUR**



LABORATORY MANUAL

REGULATED POWER SUPPLY

DR. POORAN SINGH CHOWDHARY

(M.Sc., Ph.D., LL.B.)

DEPARTMENT OF PHYSICS

***PANDIT SUNDARLAL SHARMA (OPEN) UNIVERSITY
CHHATTISGARH, BILASPUR***

OBJECT:

The purpose of the experiment is to design a +5 V DC regulated power supply delivering up to 1A of current to the load. Also to determine the load regulation and efficiency of the regulated power supply.

EQUIPMENTS AND COMPONENTS USED:

30 MHz Dual Channel Cathode Ray Oscilloscope, 3 MHz Function Generator, 0-30 V dc dual regulated power supply, Digital Multimeter, 230 V/ 9 V, 1A Step down transformer, 1N4007 Diode IC 7805, Resistor 100 Ω , ¼W, Electrolytic Capacitor 1000 μ F/25V, Ceramic Capacitor 0.33 μ F, 0.1 μ F, Breadboard and Connecting wires, BNC Cables and Probes.

THEORY:

Every electronic circuit is designed to operate off of supply voltage, which is usually constant.

A regulated power supply provides this constant DC output voltage and continuously holds the output voltage at the design value regardless of changes in load current or input voltage.

The power supply contains a rectifier, filter, and regulator. The rectifier changes the AC input voltage to pulsating DC voltage. The filter section removes the ripple component and provides an unregulated DC voltage to the regulator section.

The regulator is designed to deliver a constant voltage to the load under varying circuit conditions. The two factors that can cause the voltage across the load to vary are fluctuations in input voltage and changes in load current requirements.

Load regulation is a measurement of power supply, showing its capacity to maintain a constant voltage across the load with changes in load current.

Line regulation is a measurement of power supply, showing its capacity to maintain a constant output voltage with changes in input voltage.

DIFFERENT PARTS OF A POWER SUPPLY UNIT:

1. Transformer Section: Input a. c. voltage through a step down transformer,
2. Rectification Section: Full wave rectifier,
3. Filter Section: Series inductor or shunt capacitor filter,
4. Regulation Section: Voltage regulator in terms of IC or Zener diode and bleeder resistance,
5. Load Section: Device across the power supply.

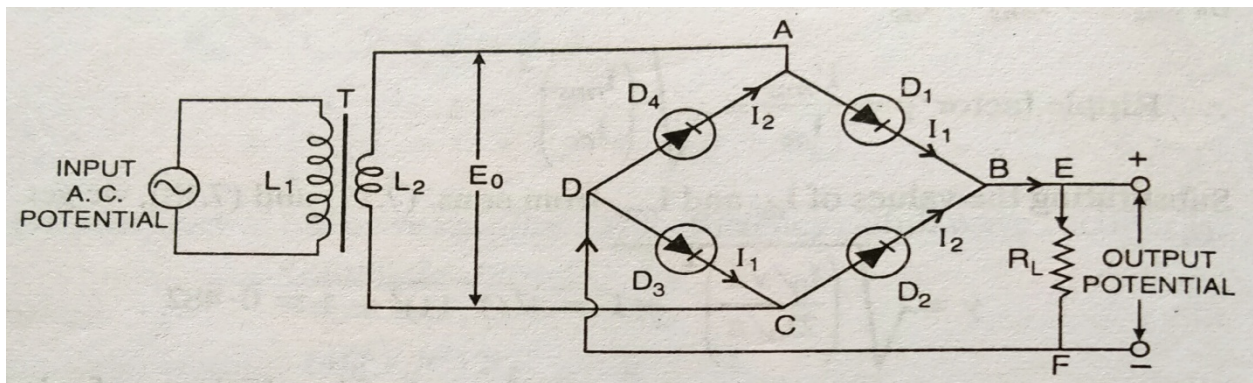

Figure 1: Circuit diagram of full wave bridge rectifier

(A) Transformer and Rectification Section:

The circuit diagram of a bridge rectifier is shown in figure 1. It is a full wave rectifier. It consists of four junction diodes which form the four arms of the bridge network. The bridge rectifier does not require centre tap in the secondary of the transformer.

(B) Filter Section:

In series inductor filter, an inductance coil or choke coil L is connected in series with the load resistance R_L . Figure 2 shows the diagram of series inductor filter.

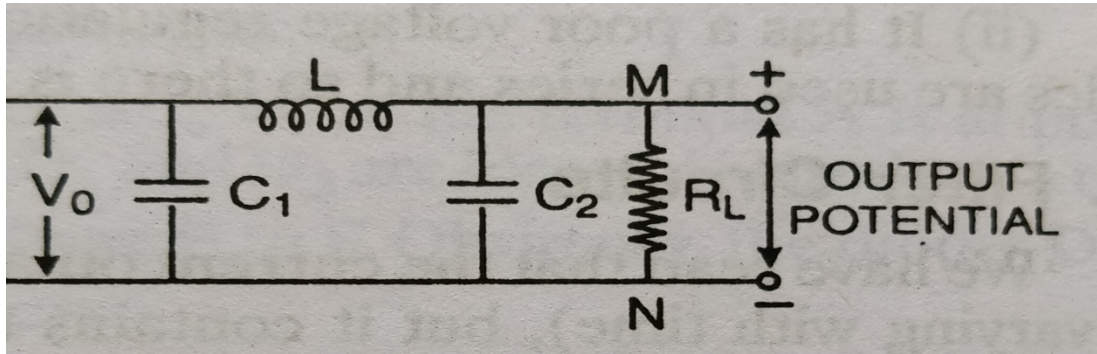

Figure 2: Diagram of series inductor filter

An inductance coil opposes the change in current passing through it. When current through the inductance coil increases from its average value, the inductor stores the energy in the form of magnetic field and the current through it decreases from its average value, this stored energy is released to the load. Thus the value of current in the circuit almost remains constant. Figure 3 shows the output current I_L obtained through the load using the series inductor filter with a full wave rectifier.

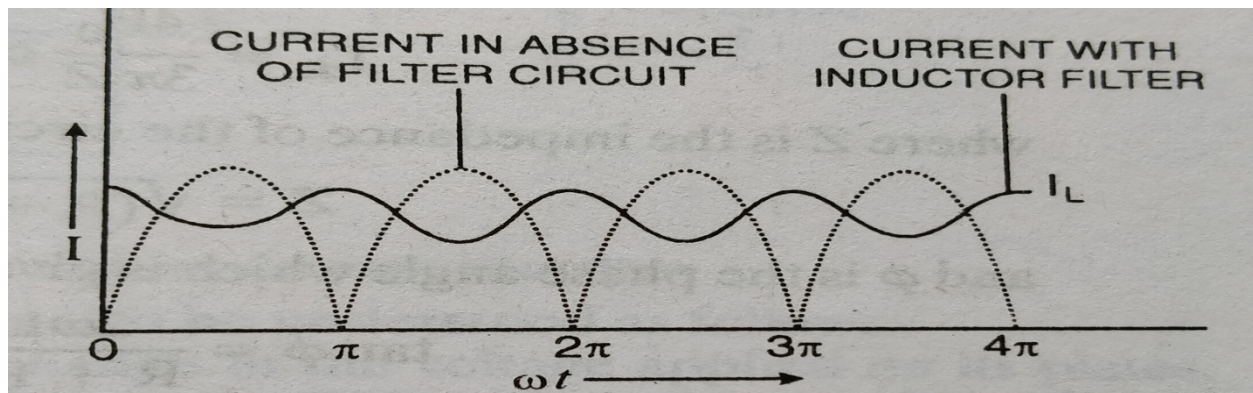

Figure 3: Output in the series inductor filter

In shunt capacitor filter, a condenser C is connected in parallel with the load resistance, R_L .

A condenser opposes the change in voltage applied on its plates. When the voltage across the condenser increases from its average value, charge accumulates on the condenser, i.e. the electrical potential energy is stored in the condenser and when the voltage across the condenser decreases below its average value, this energy stored in the condenser transforms in form of voltage (or current) and makes the voltage (or current) constant. Thus a condenser with the rectifier, stores some of the energy of the pulsating electric signal in the electric field. If the condenser is allowed to discharge during the current pulsation, fluctuations in the output voltage are reduced to a great extent, i.e. the output signal becomes smooth.

It may be mentioned here that the fall in voltage during the discharge depends on the time constant ($= CR_L$) of the condenser-load circuit. To maintain the output voltage nearly constant for the complete cycle, the fall in voltage must be very low, hence the time constant CR_L of the condenser-load circuit must be very high in comparison to the time period of the a.c. signal applied on the rectifier.

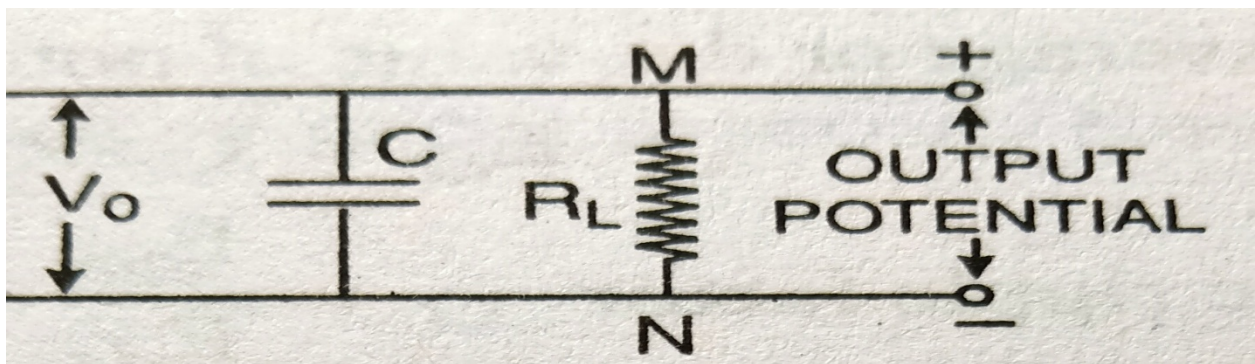

Figure 4: Diagram of shunt capacitor filter

Figure 4 shows the diagram of shunt capacitor filter.

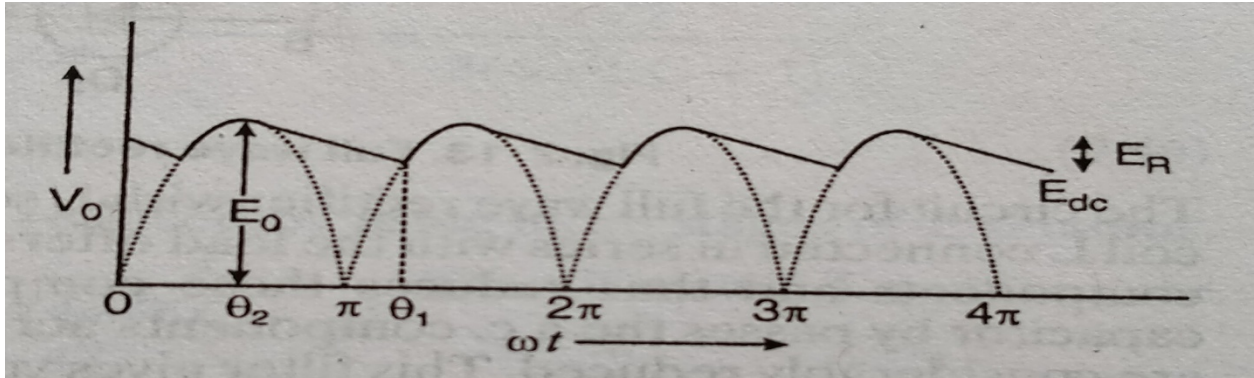

Figure 5: Output potential with capacitor filter

Figure 5 shows the time variation of output potential E_{dc} of a full wave rectifier using the capacitor filter.

(C) Regulation and Load Section:

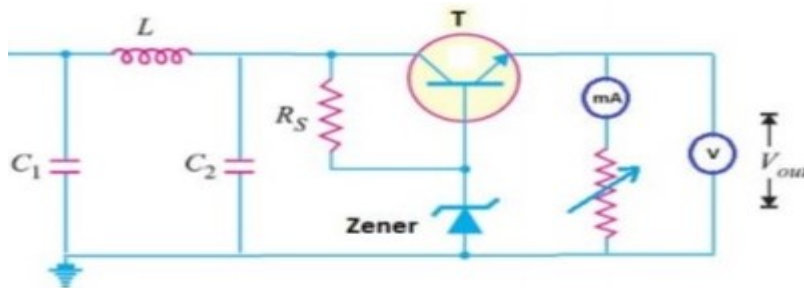

Figure 6: Circuit diagram of voltage regulator with π section filter

We know that a zener diode can be used in the reverse bias as the voltage regulator. When the reverse bias voltage on a zener diode is equal to the zener breakdown voltage, the reverse current suddenly increases, but the potential difference almost remains constant. Hence to regulate voltage, the output current from the filter circuit is first passed through a constant resistance (called the bleeder resistance) and then through the zener diode as shown in the figure 6. 7805 IC is also used for regulation of the voltage.

DESIGN:

Design a 5 V DC regulated power supply to deliver up to 1A of current to the load with 5% ripple. The input supply is 50Hz at 230 V AC.

SELECTION OF VOLTAGE REGULATOR IC:

Fixed voltage linear IC regulators are available in a variation of voltages ranging from -24V to +24V. The current handling capacity of these ICs ranges from 0.1A to 3A. Positive fixed voltage regulator ICs have the part number as 78XX. The design requires 5V fixed DC voltage, so 7805 regulator IC rated for 1A of output current is selected.

SELECTION OF BYPASS CAPACITORS:

The data sheet on the 7805 series of regulators states that for best stability, the input bypass capacitor should be $0.33\mu\text{F}$. The input bypass capacitor is needed even if the filter capacitor is used. The large electrolytic capacitor will have high internal inductance and will not function as a high frequency bypass; therefore, a small capacitor with good high frequency response is required. The output bypass capacitor improves the transient response of the regulator and the data sheet recommends a value of $0.1\mu\text{F}$.

DROPOUT VOLTAGE:

The dropout voltage for any regulator states the minimum allowable difference between output and input voltages if the output is to be maintained at the correct level. For 7805, the dropout voltage at the input of the regulator IC is $V_o + 2.5 \text{ V}$.

$$V_{\text{dropout}} = 5 + 2.5 = 7.5\text{V}$$

SELECTION OF FILTER CAPACITOR:

The filter section should have a voltage of at least 7.5V as input to regulator IC. That is $V_{\text{dc}} = 7.5 \text{ V}$

$$\text{Ripple voltage} = \Delta V = V_r$$

Two quantities of merit for power supplies are the ripple voltage V_r and the ripple factor RF.

$$RF = V_r(\text{rms}) / V_{dc}$$

$$V_r(\text{rms}) = (V_m - V_{\min}) / 2\sqrt{3} = V_r / 2\sqrt{3}$$

$$V_{dc} = 2V_m / \pi = 0.636 V_m$$

$$V_{dc} = V_m - V_r / 2 = (V_m + V_{\min}) / 2$$

$V_r = I_L \times T_{\text{off}} / C$ can be solved for the value of C.

The ripple frequency of the full-wave ripple is 100 Hz. The off-time of the diodes for 100 Hz ripple is assumed to be 85%. $T_{\text{off}} = 8.5\text{ms}$.

$$C = I_L \times T_{\text{off}} / V_r$$

SELECTION OF DIODES:

1N4007 diodes are used as it is capable of withstanding a higher reverse voltage, PIV of 1000V whereas 1N4001 has PIV of 50V.

SELECTION OF TRANSFORMER:

Maximum unregulated voltage, $V_{\text{unreg(max)}} = V_{\text{dropout}} + V_r$

Two diodes conduct in the full-wave bridge rectifier; therefore peak of the secondary voltage must be two diode drops higher than the peak of the unregulated DC.

$$V_{\text{sec(peak)}} = V_{\text{unreg(max)}} + 1.4V$$

$$V_{\text{sec(rms)}} = 0.707 \times V_{\text{sec(peak)}}$$

The power supply is designed to deliver 1A of load current, so the secondary winding of the transformer needs to be rated for 1A.

PRACTICAL CIRCUIT DIAGRAM:

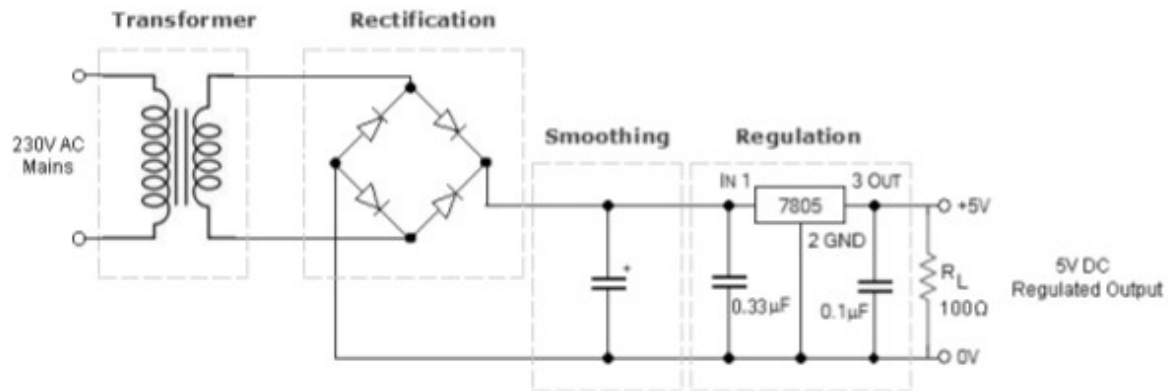

Figure 7: Circuit diagram of full wave bridge rectifier with load R_L

PROCEDURE:

A. Power Supply:

1. Connect the circuit as shown in Figure 7.
2. Apply 230V AC from the mains supply.
3. Observe the following waveforms using oscilloscope:
 - (i) Waveform at the secondary of the transformer,
 - (ii) Waveform after rectification,
 - (iii) Waveform after filter capacitor,
 - (iv) Regulated DC output.

B. Load Regulation:

1. Observe the No load voltage and Full load voltage.
2. Calculate the load regulation.

$$\text{Load Regulation} = \frac{(V_{NL} - V_{FL})}{V_{FL}} \times 100 \%$$

Theoretical efficiency of linear voltage regulator =

OUTPUT WAVE SHAPE:

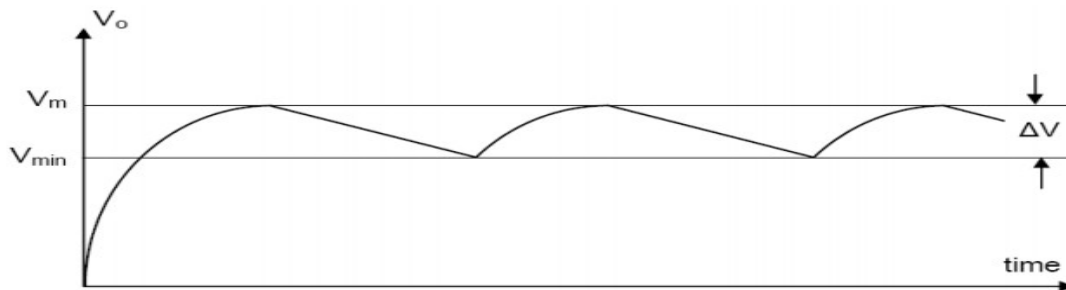

Figure 8: Output wave shape from a full-wave filtered rectifier

The voltage obtained between the output terminals is an unregulated voltage which can be read with the voltmeter connected in output circuit. The bleeder resistance which keeps the reverse bias voltage of zener diode or IC either equal to or slightly greater than its breakdown voltage. As a result, a constant (or regulated) voltage is obtained across the load. Figure 8 shows output wave shape from a full-wave filtered rectifier.

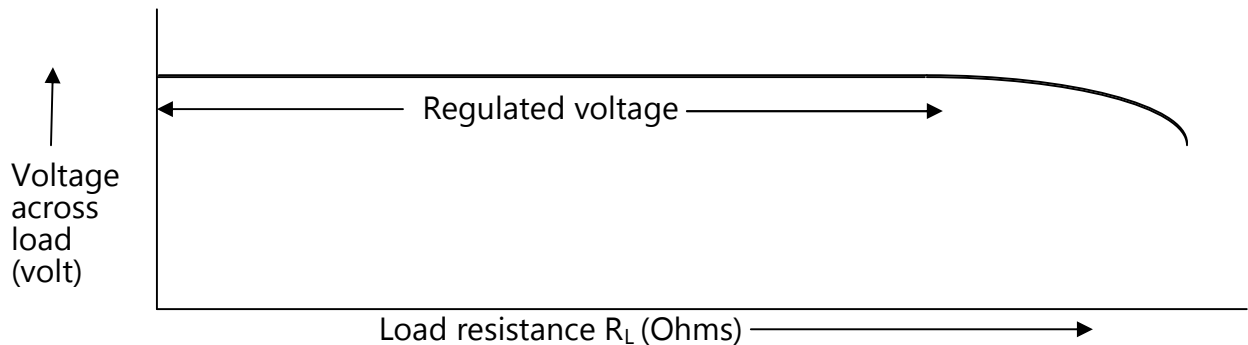

Figure 9: Output regulated voltage of full wave rectifier

RESULT: Figure 9 shows that the output of given power supply is regulated for given input AC voltage.

PRECAUTIONS:

1. All connections should be jointed correctly.
2. Connections must be tight.
3. Voltage exceeding the limit should not be applied.
4. Meters should be connected properly according to their polarities.

**PANDIT SUNDARLAL SHARMA (OPEN) UNIVERSITY
CHHATTISGARH, BILASPUR**



LABORATORY MANUAL

TO STUDY THE PN JUNCTION DIODE CHARACTERISTICS

DR. POORAN SINGH CHOWDHARY

(M.Sc., Ph.D., LL.B.)

DEPARTMENT OF PHYSICS

***PANDIT SUNDARLAL SHARMA (OPEN) UNIVERSITY
CHHATTISGARH, BILASPUR***

AIM:

To study the PN junction diode characteristics under Forward & Reverse bias conditions.

APPARATUS REQUIRED: PN Junction Kit, Ammeter, Voltmeter, connecting wires and Resistors.

THEORY:

A PN junction diode is a two terminal junction device. It conducts only in one direction (only on forward biasing).

FORWARD BIAS:

On forward biasing, initially no current flows due to barrier potential. As the applied potential exceeds the barrier potential the charge carriers gain sufficient energy to cross the potential barrier and hence enter the other region. The holes, which are majority carriers in the P-region, become minority carriers on entering the N-regions, and electrons, which are the majority carriers in the N-region, become minority carriers on entering the P-region. This injection of Minority carriers results in the current flow, opposite to the direction of electron movement.

REVERSE BIAS:

On reverse biasing, the majority charge carriers are attracted towards the terminals due to the applied potential resulting in the widening of the depletion region. Since the charge carriers are pushed towards the terminals no current flows in the device due to majority charge carriers. There will be some current in the device due to the thermally generated minority carriers. The generation of such carriers is independent of the applied potential and hence the current is constant for all increasing reverse potential. This current is referred to as Reverse Saturation Current

(I_0) and it increases with temperature. When the applied reverse voltage is increased beyond the certain limit, it results in breakdown. During breakdown, the diode current increases tremendously.

CIRCUIT DIAGRAM:

FORWARD BIAS:

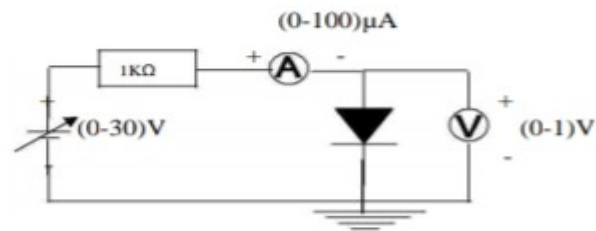

REVERSE BIAS:

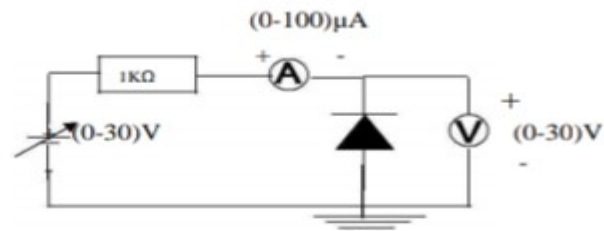

PROCEDURE:

FORWARD BIAS:

1. Connect the circuit as per the diagram.
2. Vary the applied voltage V in steps of 0.1V.
3. Note down the corresponding Ammeter readings I_f .
4. Plot a graph between V_f and I_f .

OBSERVATION TABLE:

Forward Bias			Reverse Bias		
S. No.	Voltage V_f (in Volts)	Current I_f (in μA)	S. No.	Voltage V_r (in Volts)	Current I_r (in μA)

OBSERVATIONS:

1. Find the dc. (Static) resistance = $V_f / I_f =$
2. Find the ac. (Dynamic) resistance $r = \delta V / \delta I$ ($r = V / I$) = $(V_2 - V_1) / (I_2 - I_1) =$
3. Find the forward voltage drop = [Hint: it is equal to 0.7 for Si and 0.3 for Ge]=

REVERSE BIAS:

1. Connect the circuit as per the diagram.
2. Vary the applied voltage V_r in steps of 0.5V.
3. Note down the corresponding Ammeter readings I_r .
4. Plot a graph between V_r & I_r .
5. Find the dynamic resistance $r = \delta V / \delta I$.

FORMULA FOR REVERSE SATURATION CURRENT (I_o):

$$I_o = \delta I / [\exp (\delta V / \eta V_T)] - 1$$

Where V_T is the voltage equivalent of Temperature = kT/q

k is Boltzmann's constant, q is the charge of the electron and T is the temperature in degrees Kelvin.

$\eta = 1$ for Silicon and 2 for Germanium

MODEL GRAPH:

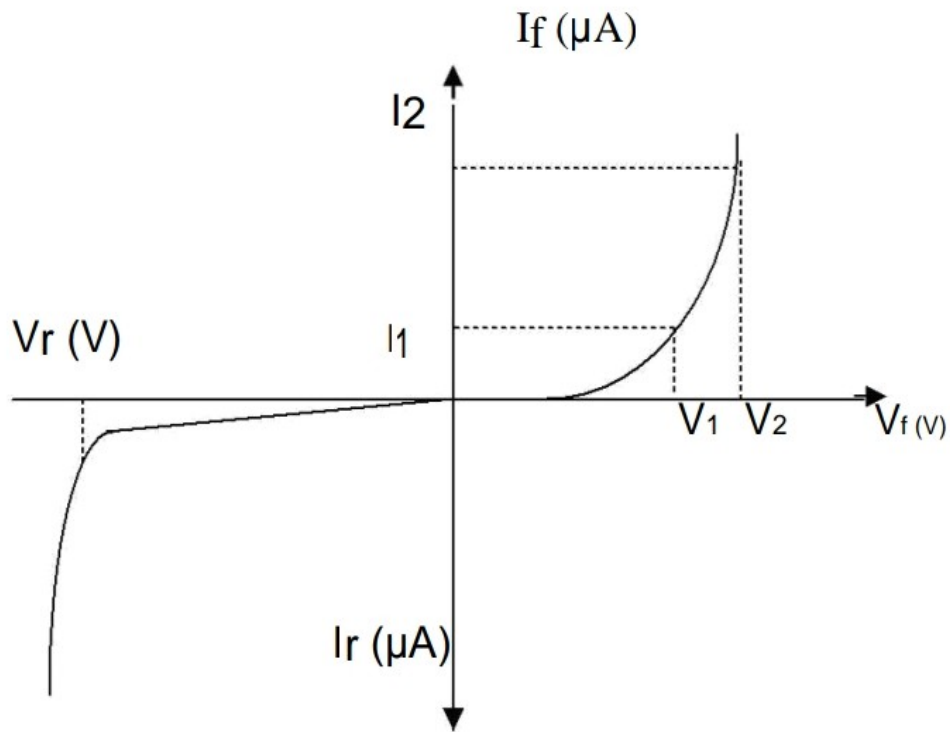

RESULT:

Forward and Reverse bias characteristics of the PN junction diode was Studied and the dynamic resistance under

Forward bias = -----

Reverse bias = -----

Reverse Saturation Current = -----

PRECAUTIONS:

1. The two terminals of the diode must be fully identified.
2. Practically diode contains two terminals, which are called p terminal and n terminal.
3. PN junction diode should always be used in forward and reversed bias.
4. Voltage exceeding the limit should not be applied.

**PANDIT SUNDARLAL SHARMA (OPEN) UNIVERSITY
CHHATTISGARH, BILASPUR**



LABORATORY MANUAL

FIELD EFFECT TRANSISTOR (FET) CHARACTERISTICS

DR. POORAN SINGH CHOWDHARY

(M.Sc., Ph.D., LL.B.)

DEPARTMENT OF PHYSICS

***PANDIT SUNDARLAL SHARMA (OPEN) UNIVERSITY
CHHATTISGARH, BILASPUR***

FET CHARACTERISTICS

AIM:

- a) To Draw the drain and transfer characteristics of a given FET.
- b) To find the drain resistance (r_d) amplification factor (μ) and Transconductance (g_m) of the given FET.

APPARATUS:

FET, regulated power supply, voltmeter (0-20V), ammeter (0-100mA), bread Board and connecting wires.

THEORY:

The Field Effect Transistor or Simply FET uses the voltage that is applied to their input terminal, called the Gate to control the current flowing through them resulting in the output current being proportional to the input voltage, the Gates to source junction of the FET is always reversed biased. As their operation relies on an electric field (hence the name field effect) generated by the input Gate voltage, this then makes the Field Effect Transistor a "VOLTAGE" operated device.

The Field Effect Transistor is a three terminal unipolar semiconductor device that has very similar characteristics to those of their Bipolar Transistor counterpart's i.e., high efficiency, instant operation, robust and cheap and can be used in most electronic circuit applications to replace their equivalent bipolar junction transistors (BJT).

The Field Effect Transistor has one major advantage over its standard bipolar transistor, in that input impedance, (R_{in}) is very high, (thousands of Ohms). This very high input impedance makes them very sensitive to input voltage signals.

There are two basic configurations of junction field effect transistor, the N-channel JFET and the P-channel JFET. The N-channel JFET's channel is

doped with donor impurities meaning that the flow of current through the channel is negative (hence the term N-channel) in the form of electrons.

A FET is a three terminal device, having the characteristics of high input impedance and less noise, the Gate to Source junction of the FET is always reverse biased. In amplifier application, the FET is always used in the region beyond the pinch-off.

In response to small applied voltage from drain to source, then n-type bar acts as simple resistor, and the drain current increases linearly with VDS. With increase in ID the ohmic voltage drop between the source and the channel region reverse biases the junction and the conducting position of the channel begins to remain constant. The VDS at this instant is called "pinch of voltage" (see figure). If the gate to source voltage (VGS) is applied in the direction to provide additional reverse bias, the pinch off voltage is decreased.

TRANSFER OR TRANSCONDUCTANCE CHARACTERISTICS:

Transfer characteristics are useful in evaluating the operating conditions of an FET.

Drain current in the active region.

$I_D = I_{DSS} [1 - V_{GS} / V_P]^2$ this is Square Law.

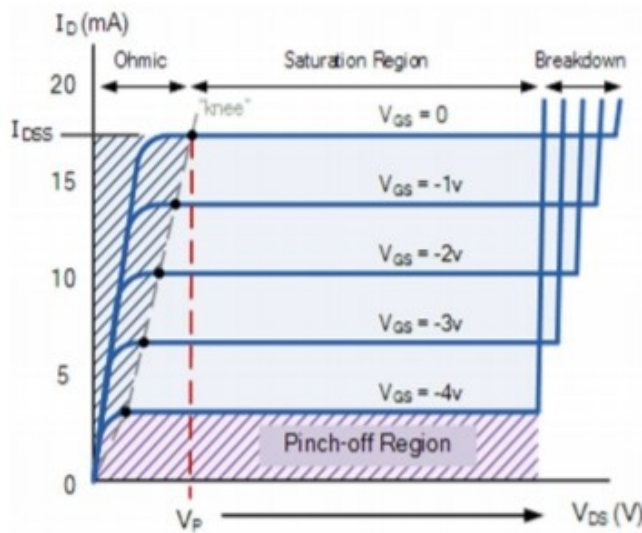
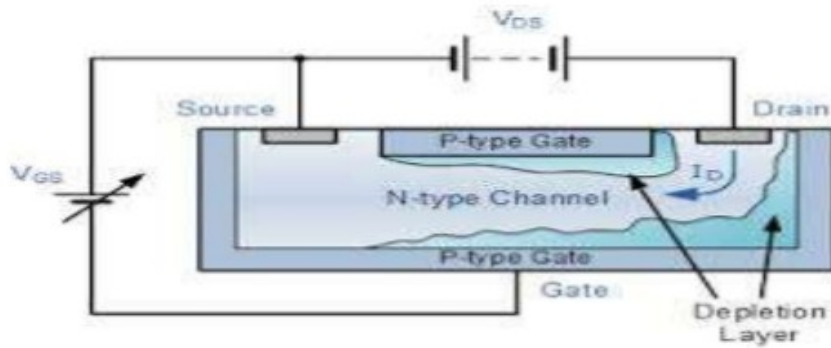

The characteristics curves example shown above, shows the four different regions of operation for a JFET and these are given as:

- Ohmic Region-When $V_{GS} = 0$ the depletion layer of the channel is very small and the JFET acts like a voltage controlled resistor.

- Cut-off region- This is also known as the pinch-off region where the Gate Voltage, V_{GS} is sufficient to cause the JFET to act as an open circuit as the channel resistance is at maximum.

- Saturation or Active Region – The JFET becomes a good conductor and is controlled by the Gate-Source voltage, (V_{GS}) while the Drain-Source voltage, (V_{DS}) has little or no effect.

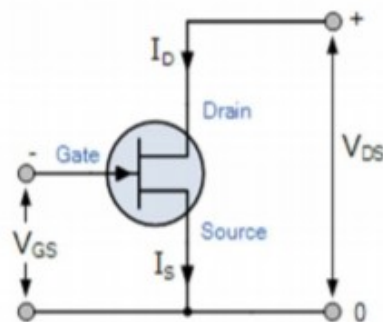

- Breakdown Region-The voltage between the Drain and the Source, (V_{DS}) is high enough to cause the JFET's resistive channel to break down and pass uncontrolled maximum current.

CIRCUIT DIAGRAM:

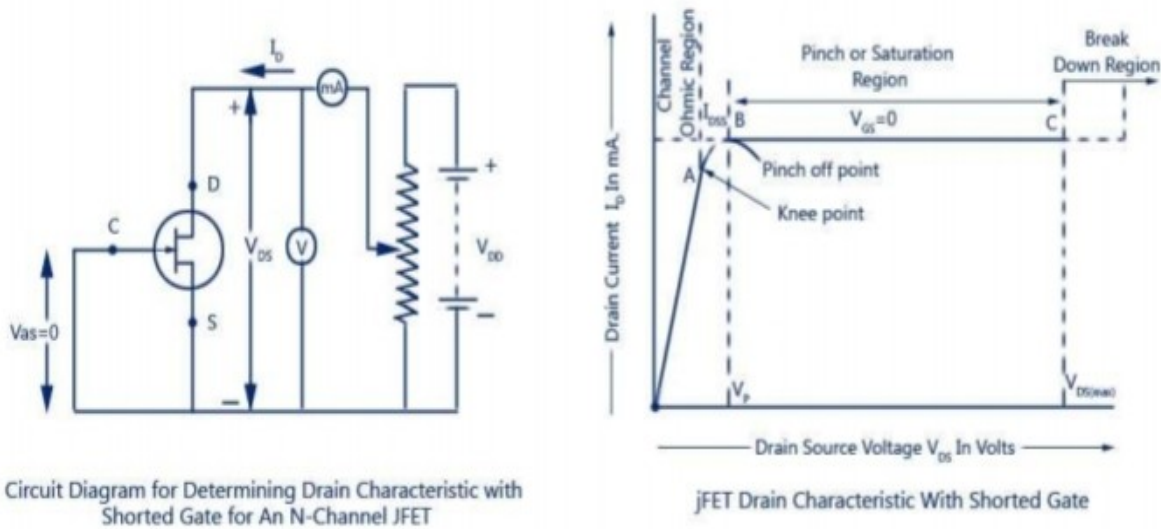

Drain characteristics of JFET

PROCEDURE:

1. All the connections are made as per the circuit diagram.
2. To plot the drain characteristics keep V_{GS} constant at 0V.
3. Vary the V_{DD} and observe the values of V_{DS} and I_D .
4. Repeat the above steps 2, 3 for different values of V_{GS} at 0.1V and 0.2V.
5. All the readings are tabulated.
6. To plot the transfer characteristics, keep V_{DS} constant at 1V.
7. Vary V_{GS} and observe the values of V_{GS} and I_D .
8. Repeat steps 6 and 7 for different values of V_{DS} at 1.5V and 2V.
9. The readings are tabulated.

10. From drain characteristics, calculate the values of dynamic resistance (r_d) by using the formula $r_d = \Delta V_{DS} / \Delta I_D$

11. From transfer characteristics, calculate the value of Trans conductance (g_m) by using the formula $g_m = \Delta I_D / \Delta V_{GS}$

12. Amplification factor (μ) = dynamic resistance * Tran conductance*

$$\mu = \Delta V_{DS} / \Delta V_{GS}$$

OBSERVATION TABLES:

DRAIN CHARACTERISTICS

S.NO.	$V_{GS}=0V$		$V_{GS}=-1V$		$V_{GS}=-2V$	
	$V_{DS}(V)$	$I_D(mA)$	$V_{DS}(V)$	$I_D(mA)$	$V_{DS}(V)$	$I_D(mA)$

TRANSFER CHARACTERISTICS

S.NO.	$V_{DS}=0.5V$		$V_{DS}=1V$		$V_{DS}=1.5V$	
	$V_{GS}(V)$	$I_D(mA)$	$V_{GS}(V)$	$I_D(mA)$	$V_{GS}(V)$	$I_D(mA)$

MODEL GRAPH: TRANSFER CHARACTERISTICS

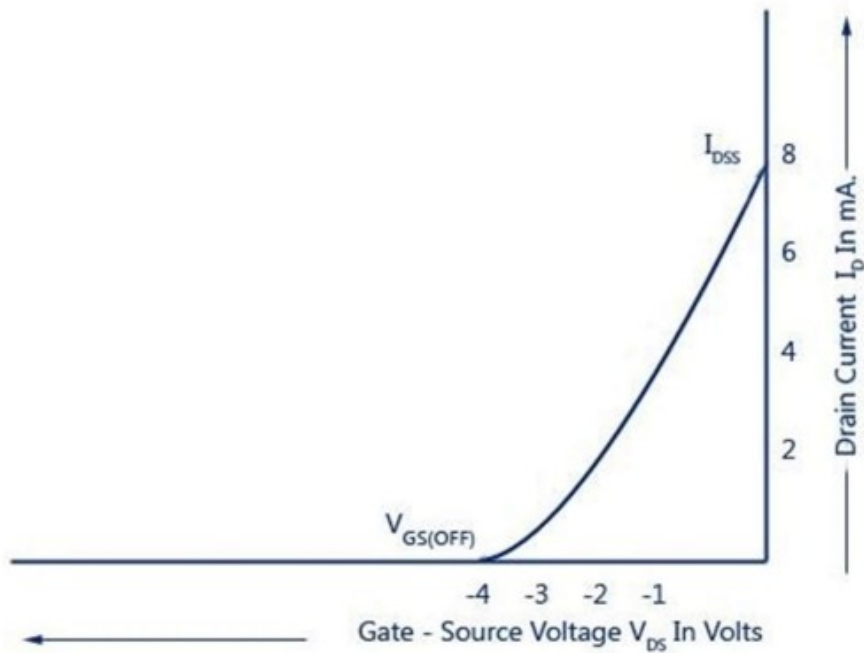

Transfer Characteristics of JFET

DRAIN CHARACTERISTICS

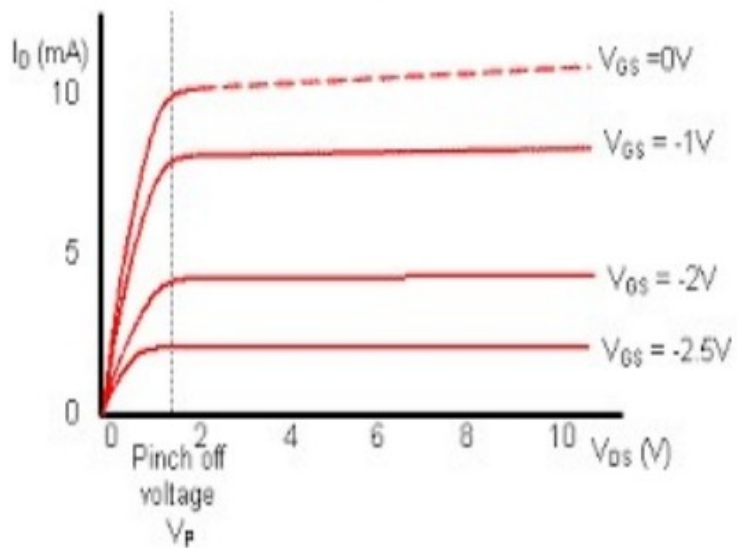

TRANSFER OR TRANSCONDUCTANCE CHARACTERISTICS:

Transfer characteristics are useful in evaluating the operating conditions of an FET. Drain current in the active region.

$$I_D = I_{DSS} [1 - V_{GS} / V_P]^2$$

This is Square Law.

RESULT:

1. The drain and transfer characteristics of a given FET are drawn.
2. The dynamic resistance (r_d), amplification factor (μ) and Trans conductance (g_m) of the given FET are calculated.

PRECAUTIONS:

1. The three terminals of the FET must be fully identified.
2. Practically FET contains four terminals, which are called source, drain, Gate, substrate.
3. Source and gate should be short circuited.
4. Voltage exceeding the ratings of the FET should not be applied.

TRANSFER OR TRANSCONDUCTANCE CHARACTERISTICS:

Transfer characteristics are useful in evaluating the operating conditions of an FET. Drain current in the active region.

$$I_D = I_{DSS} [1 - V_{GS} / V_P]^2$$

This is Square Law.

RESULT:

1. The drain and transfer characteristics of a given FET are drawn.
2. The dynamic resistance (r_d), amplification factor (μ) and Transconductance (g_m) of the given FET are calculated.

PRECAUTIONS:

1. The three terminals of the FET must be fully identified.
2. Practically FET contains four terminals, which are called source, drain, Gate, substrate.
3. Source and gate should be short circuited.
4. Voltage exceeding the ratings of the FET should not be applied.

VERIFIED



Dr. Anita Singh
Incharge NAAC Criteria
PSSOU, CG Bilaspur